

ON PACKING SQUARES WITH EQUAL SQUARES

by

P. Erdős
R. L. Graham

STAN-CS-75-483
MARCH 1975

COMPUTER SCIENCE DEPARTMENT
School of Humanities and Sciences
STANFORD UNIVERSITY

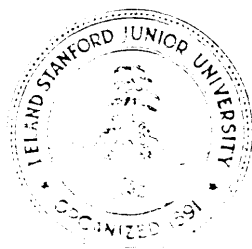

ON PACKING SQUARES WITH EQUAL SQUARES

P. Erdős
Stanford University
and
The Hungarian Academy of Sciences
and

R. L. Graham
Stanford University
and
Bell Laboratories, Murray Hill, New Jersey

Abstract

The following problem arises in connection with certain multi-dimensional stock cutting problems:

How many non-overlapping open unit squares may be packed into a large square of side α ?

Of course, if α is a positive integer, it is trivial to see that α^2 unit squares can be successfully packed. However, if α is not an integer, the problem becomes much more complicated. Intuitively, one feels that for $\alpha = N + \frac{1}{100}$, say, (where N is an integer), one should pack N^2 unit squares in the obvious way and surrender the uncovered border area (which is about $\alpha/50$) as unusable waste. After all, how could it help to place the unit squares at all sorts of various skew angles?

In this note, we show how it helps. In particular, we prove that we can always keep the amount of uncovered area down to at most proportional to $\alpha^{7/11}$, which for large α is much less than the linear waste produced by the "natural" packing above.

This research was supported in part by National Science Foundation grant GJ 36473X and by the Office of Naval Research contract NR 044-402. Reproduction in whole or in part is permitted for any purpose of the United States Government.

ON PACKING SQUARES WITH EQUAL SQUARES

by

P. Erdős
Stanford University
and
The Hungarian Academy of Sciences

and

R. L. Graham
Bell Laboratories
Murray Hill, New Jersey

If two non-overlapping squares are inscribed in a unit square, then the sum of their circumferences is at most 4 , the circumference of the unit square. As far as we know, this was first published by P. Erdős and appeared as a problem in a mathematical paper for high school students in Hungary. A. Beck and M. N. Bleicher [1] proved that if a closed convex curve \mathcal{C} has the property that for every two inscribed non-overlapping similar curves \mathcal{C}_1 and \mathcal{C}_2 , the sum of the circumferences of \mathcal{C}_1 and \mathcal{C}_2 is not greater than the circumference of \mathcal{C} , then \mathcal{C} is either a regular polygon or a curve of constant width.

It is clear that one can inscribe k^2 squares into a unit square so that the sum of their circumferences is $4k$. P. Erdős conjectured 40 years ago that if we inscribe $k^2 + 1$ squares into a unit square, the total circumference remains at most $4k$. For $k = 1$, this is true as we have just stated. D. J. Newman [2] proved the conjecture for $k = 2$ but the general case is still unsettled.

Denote by $f(\ell)$ the maximal sum of circumferences of ℓ non-overlapping squares packed into a unit square. The conjecture we cannot prove is just $f(k^2+1) = 4k$. In this note we show $f(\ell) > 4k$ for $\ell = k^2 + o(k)$, (in fact, for $a = k^2 + [ck^{7/11}]$ using just equal squares). We do not know as $f(\ell)$ increases from $4k$ to $4k + 4$ how large the jumps are and where they occur.

Instead of maximizing the circumference sum of packings of a unit square by arbitrary squares, we shall work with the closely related problem of maximizing the area sum of packings of an arbitrary square by unit squares.

For each positive real α , define

$$W(\alpha) = \alpha^2 - \sup_{\rho} |\rho|$$

where ρ ranges over all packings of unit squares into a given square $S(\alpha)$ of side α and $|\rho|$ denotes the number of unit squares in ρ .

Theorem.

$$(1) \quad W(\alpha) = O(\alpha^{7/11})$$

Proof: We sketch a construction which will prove (1). As usual, the notation $f(x) = O(g(x))$ will denote the existence of two positive constants c and c' such that $cg(x) < f(x) < c'g(x)$ for all sufficiently large x .

We begin by packing $S(\alpha)$ with N^2 unit squares which form a subsquare $S(N)$ in the lower left-hand corner of $S(\alpha)$ as shown in Fig. 1, where $N = [\alpha^{-8/11}]$ and α is large. The remaining uncovered area can be decomposed into two rectangles, each having width $\beta = \alpha - N$ and lengths $> N$.

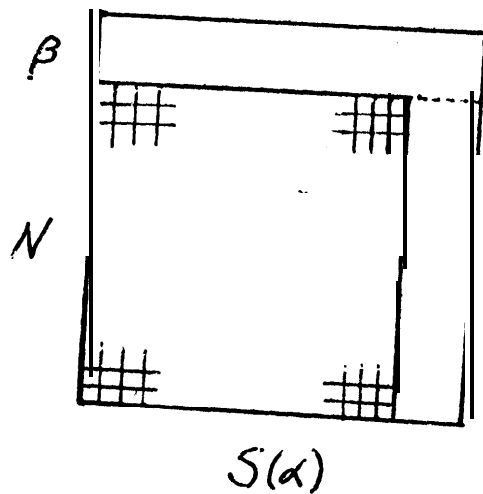

Fig. 1

Next, we pack a rectangle $R(\beta, \gamma)$ of sides β and γ with $\gamma = \Omega(\alpha)$, $\beta = \Omega(\alpha^{8/11})$ as follows. Let $n = [\beta]$. Place adjacent parallel rectangles $R(1, n+1)$, each formed from $n+1$ unit squares, tilted at the appropriate angle θ so that all $R(1, n+1)$'s touch both the top and bottom edges of $R(\beta, \gamma)$. Furthermore, place these so that $D = \Omega(\alpha^{2/11})$ (see Fig. 2). Note that $D' = \Omega(\alpha^{4/11})$.

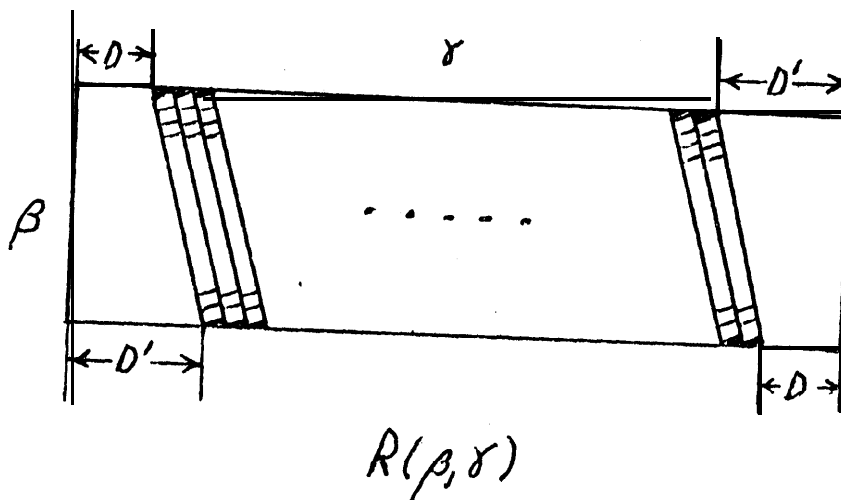

Fig. 2

An easy calculation shows that $\theta = \Omega(\alpha^{-4/11})$ and so, each of the small shaded right triangles on the border of R has area $\Omega(\alpha^{-4/11})$. The total area of the triangles is therefore $\Omega(\alpha^{7/11})$.

There are, in addition, two right trapezoids T with base β and vertical sides D and D' which have not been covered up to this point. We next describe how to pack T .

Let $m = \lfloor \alpha^{4/11} \rfloor$. Starting from the right-hand side of T , partition T into as many right trapezoids T_1, T_2, \dots, T_r as possible, where the base of each T_k is m (see Fig. 3).

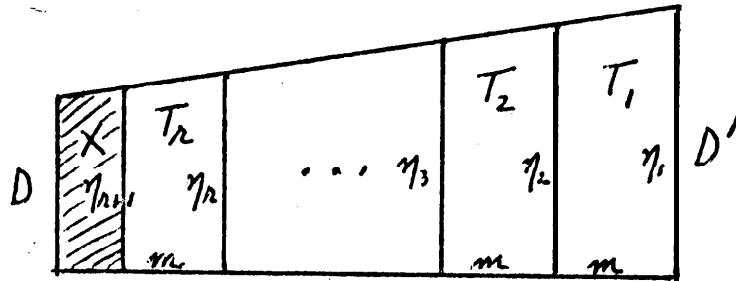

Fig. 3

Thus, $r = \Omega(\alpha^{4/11})$ and X has area $O(\alpha^{6/11})$. If the vertical sides of T_k are η_k and η_{k+1} , let $h_k = \lfloor \eta_k - \alpha^{2/11} \rfloor$. Pack the bottom subrectangle $R(m, h_k)$ of T_k with mh_k unit squares in the natural way (as shown in Fig. 4) and let T_k^* denote the remaining uncovered subtrapezoid of T_k .

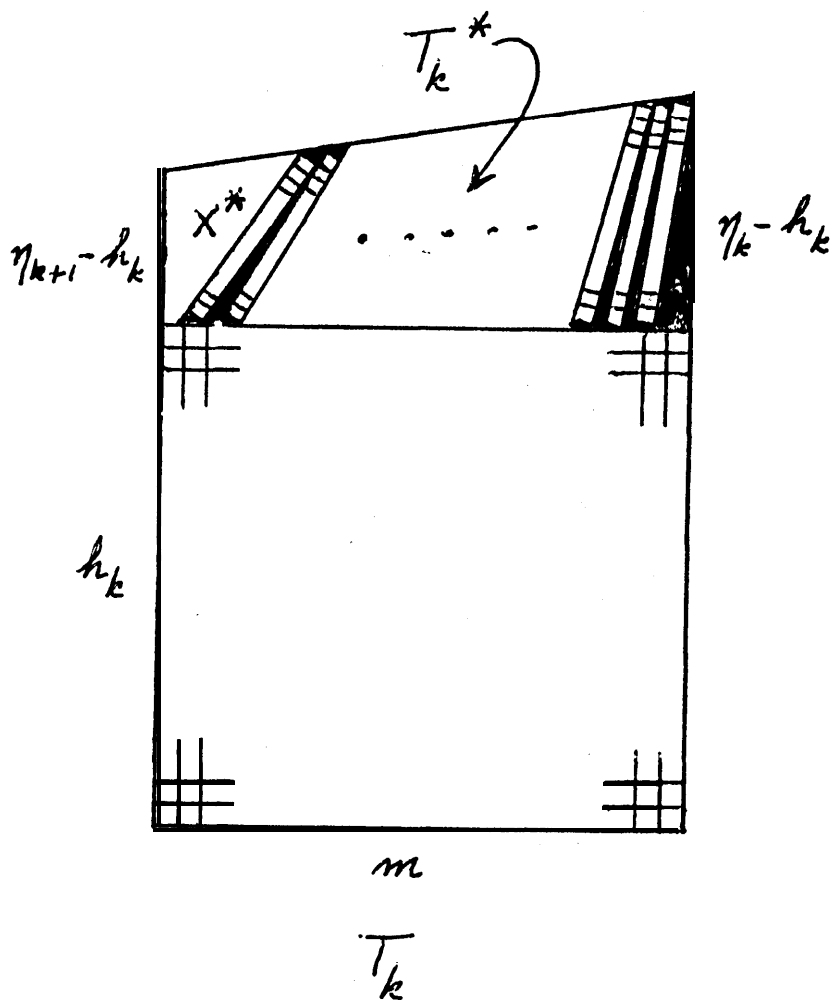

Fig. 4

Now, for $s_k = [\eta_k] - h_k$, pack T_k^* with rectangles $R(1, s_k + 1)$ as shown in Fig. 4. Here, each $R(1, s_k + 1)$ touches both the top and bottom edges of T_k as well as the adjacent $R(1, s_k + 1)$'s. As before, the uncovered border right triangles on T_k^* have total area $m \Omega(\alpha^{-1/11}) = \Omega(\alpha^{3/11})$. The total area of the triangular regions between adjacent $R(1, s_k + 1)$'s is also just $\Omega(\alpha^{3/11})$ since the sum of the angles at the top vertices is $\Omega(\alpha^{-1/11})$. Finally, the uncovered triangle X^* has area $\Omega(\alpha^{3/11})$. Since $r = \Omega(\alpha^{4/11})$ then the total uncovered area in T is just $r \Omega(\alpha^{3/11}) + \Omega(\alpha^{6/11}) = \Omega(\alpha^{7/11})$.

Hence the total uncovered area of $S(\alpha)$ is just $O(\alpha^{7/11})$ and the theorem is proved. ■

The previously mentioned assertion that $f(k^2 + ck^{7/11}) > 4k$ follows immediately. It is rather annoying that we do not at present have any nontrivial lower estimate for $W(\alpha)$. Indeed we cannot even rule out the possibility that $W(\alpha) = O(1)$. Perhaps the correct bound is $O(\alpha^{1/2})$.

In the same spirit the following questions can be asked. Let \mathcal{C} be closed convex curve of circumference 1. Inscribe k non-overlapping curves in \mathcal{C} which are all similar to \mathcal{C} . Denote by $f(\mathcal{C}, k)$ the maximum of the sum of the circumferences of these curves. If \mathcal{C} is a parallelogram or a triangle then clearly $f(\mathcal{C}, \ell^2) = \ell$. All that is needed is that \mathcal{C} can be covered with ℓ^2 copies of \mathcal{C} . We do not know for which figures other cases of exact coverings are possible for other values of k although for every k , there are \mathcal{C} 's which have an exact covering into k parts, e.g., a rectangle. The following questions can be posed: For which \mathcal{C} is the growth of $f(\mathcal{C}, k)$ the slowest? Could this \mathcal{C} be a circle? Which \mathcal{C} permit exact coverings? Which \mathcal{C} permit exact coverings with congruent curves similar to \mathcal{C} ? For such \mathcal{C} , let $1 < n_1 < n_2 < \dots$ be the integers for which such an exact covering is possible. What can be said about these sequences? For example, can $nk = o(k^2)$?

REFERENCES

- [1] A. Beck and M. N. Bleicher, Packing convex sets into a similar set, Acta. Math. Hung. Acad. Sci. 22 (1972) 283-303.
- [2] D. J. Newman (personal communication).