

A STRUCTURAL MODEL FOR DATABASE SYSTEMS

by

Gio Wiederhold and Ramez El-Masri

STAN-CS-79-722

February 1979

COMPUTER SCIENCE DEPARTMENT
School of Humanities and Sciences
STANFORD UNIVERSITY





A STRUCTURAL MODEL FOR DATABASE SYSTEMS

Gio Wiederhold
Ramez El-Masri

Computer Science Department
Stanford University



ABSTRACT

This report presents a model to be used for database design. Because our motivation extends to providing guidance for the structured implementation of a database, we call our model the **Structural Model**. We derive the design using criteria of correctness, relevance, and performance from semantic and operational specifications obtained from multiple sources. These sources typically correspond to prospective users or user groups of the database. The integration of such specifications is a central issue in the development of an integrated structural database model.

The structural model is used for the design of the logical structures that represent a real-world situation. However, it is not meant to represent all possible real-world semantics, but a subset of the semantics which are important in database modelling.

The model uses relations as building blocks, and hence can be considered as an extension of Codd's relational model [Codd70]. The main extensions to the relational model are the explicit representation of logical connections between relations, the inclusion of insertion-deletion constraints in the model itself, and the separation of relations into several structural types.

Connections between relations are used to represent existence dependencies of tuples in different relations. These existence dependencies are important for the definition of semantics of relationships between classes of real-world entities. The connections between relations are used to specify these existence dependencies, and to ensure that they remain valid when the database is updated. Hence, connections implicitly define a basic, limited set of integrity constraints on the database, those that identify and maintain existence dependencies among tuples from different relations. Consequently, the rules for the maintenance of the structural integrity of the model under insertion and deletion of tuples are easy to specify.

Structural relation types are used to specify how each relation may be connected to other relations in the model. Relations are classified into five types: primary relations, referenced relations, nest relations, association relations, and lexicon relations. The motivation behind the choice of these relation types is discussed, as is their use in data model design.

A methodology for combining multiple, overlapping data models — also called user views in the literature — is associated with the structural model. The database model, or conceptual schema, which represents the integrated database, may thus be derived from the individual data models of the users. We believe that the structural model can be used to represent the data relationships within the conceptual schema of the ANSI/SPARC DBMS model since it can support database submodels, also called external schema, and maintain the integrity of the submodels with respect to the integrity constraint expressible in the structural model.

We then briefly discuss the use of the structural model in database design and implementation. The structural model provides a tool to deal effectively with the complexity of large, real-world databases.

We begin this report with a very short review of existing database models. In Chapter 2, we state the purpose of the model, and in Chapter 3 we describe the structural model, first informally and then using a formal framework based on extensions of the relational model. Chapter 4 defines the representations we use, and Chapter 5 covers the integration of data models that represent the different user specifications into an integrated database model. Formal descriptions and examples of the prevalent cases are given.

The work is then placed into context first relative to other work (Chapter 6) and then briefly within our methodology for database design (Chapter 7).

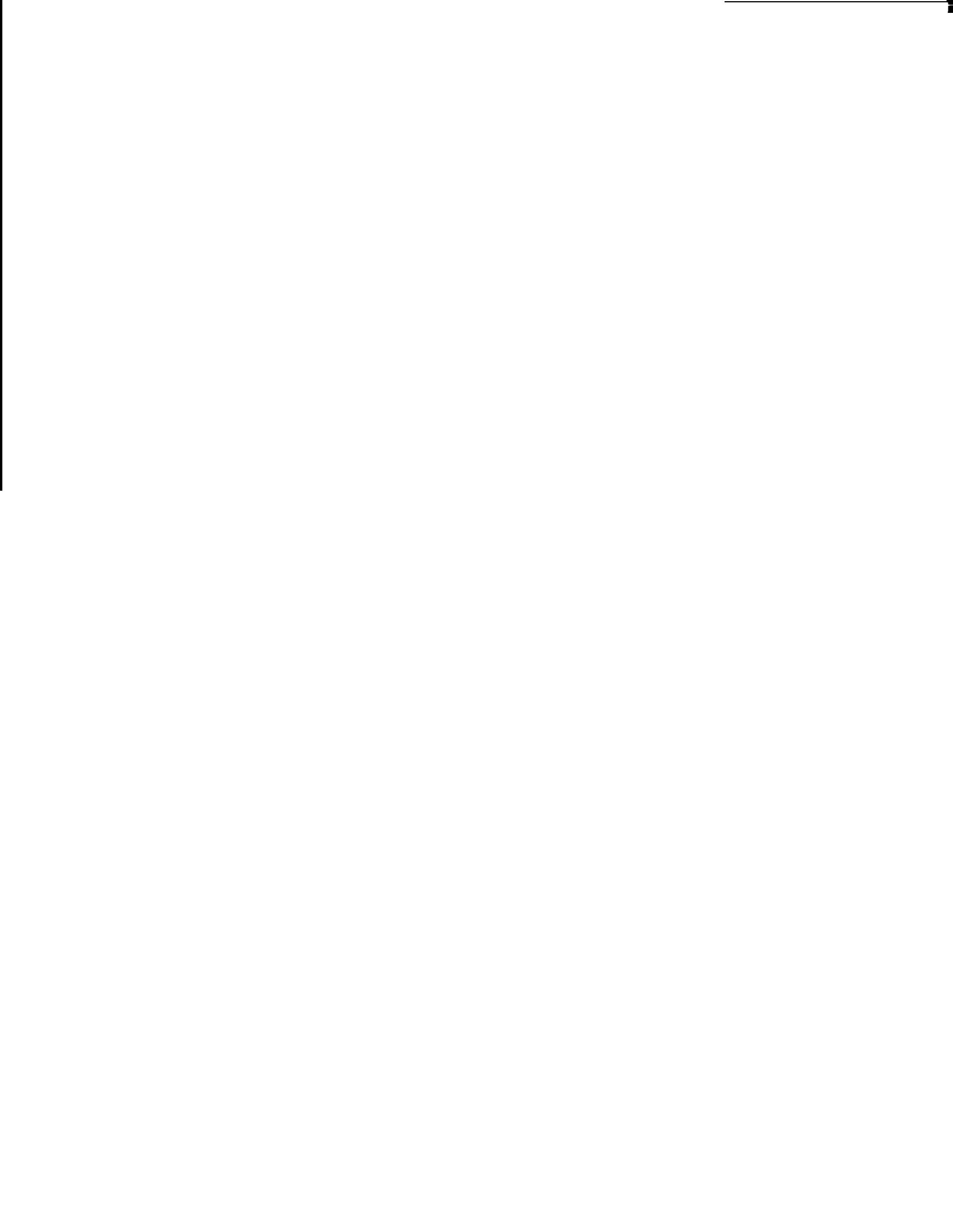

CONTENTS

1.	Current state of database models	1
1.1.	The relational model	1
1.2.	The hierarchical model	1
1.3.	The network model	2
1.4.	Some other models	2
2.	Purpose of the structural model	4
3.	The structural model	5
3.1.	Real-world structures	5
3.2.	Relations and connections	6
3.2.1.	Relations	6
3.2.2.	Connections	7
3.3.	Types of relations	9
3.3.1.	Primary entity relations	9
3.3.2.	Referenced entity relations	10
3.3.3.	Nest relations	10
3.3.4.	Lexicon relations'	11
3.3.5.	Association relations'	12
3.4.	Formal definition of relation types	12
3.4.1.	Basic relation types	12
3.4.2.	Subrelations	15
3.5.	Maintaining the structural integrity of the data model	16
3.5.1.	Update constraints in the structural model	16
3.5.2.	Data model update algorithm	18
3.5.2.1.	Tuple insertion algorithm	18
3.5.2.2.	Tuple deletion algorithm	18
3.5.2.3.	Attribute update algorithm	19
4.	Representation of data models	20
4.1.	Representation of relationships' in' the structural model	20
4.2.	Representation of a relationship between two entity classes	22
5.	Integration of data models	26
5.1.	Concepts of integration	26
5.2.	Integration of different representations of entity classes	28
5.2.1.	Recognition of relations that represent the same entity class	28
5.2.2.	Integration of relations that contain different attributes	28
5.2.3.	Integration of relations that represent different sets of tuples	28
5.3.	Integration of different representations of a relationship	30
5.3.1.	Integration with an association	30
5.3.2.	Integration with a nest of references	35
5.3.3.	Integration with a reference	41
5.3.4.	Integration with a nest	44
6.	Relationship to other models	47
7.	The database design process	49
8.	Conclusions	51



1. CURRENT STATE OF DATA MODELS

Database systems **have** become a major topic of interest because of their widespread use in industry, commerce, government, and **educational** institutions [Steel74, Sibley76, Fry76]. Several data models **have been** proposed to represent the structure of databases. The most widely discussed models are the relational model [Codd70], the hierarchical model [Tsichritzis76], and the network model (derived from the CODASYL database system specification [CODASYL74]). **The** majority of implemented database systems **use** one of the above models. For an excellent introduction to these **three** database models, **see** [CompSurv76].

1.1. The relational model:

The relational model is **formed** from relations. Each relation is composed of a set of structurally identical tuples. Tuples are composed of related data elements. For each relation, a relation description, or schema, defines **the** attributes and the possible values for **the** data elements that each tuple in the relation may take. **The** sets of tuples in a relation is described using the mathematical theory of relations, augmented with **the** concept of functional dependency among attributes. **The** mathematical basis of **the** relational model, the uniform representation of all structures as relations, and the syntactic clarity of the data model schema provide important advantages for model and query analysis.

The relational model has **been** subjected to intensive theoretical scrutiny. Third normal form [Codd72], and Boyce-Codd normal form [Codd74] have been defined to design relations with favorable update properties. Bernstein [Bernstein75] describes an algorithm for synthesis of third normal form relations from functional dependencies. Fagin [Fagin77] introduced multivalued dependencies and a fourth normal form for relations to extend the understanding of the **logical** design of relational databases.

When relations are built solely from the functional or multivalued dependencies among all attributes in the data model, several possible **logical** data models can be derived [Bernstein75, Fagin77, Chang78, Delobel78]. Further, **some** of **the** data models will not have a direct **correspondence** with **the** actual real-world situation being modeled [Schmid75]. Then the database designer, or **some** automatic procedure, has to choose the **most** suitable model.

A drawback of **the** basic relational model is that known relationships among entities of the situation being modeled are not explicitly represented but have to be recognized at query processing **time** by matching attributes that have the **same** domain. This requires recognition of similar domains, using the schema, as well as some computation within the database to match data **elements**. Also, logical integrity constraints are not defined within **the** model, but are left to **be** defined by **the** database implementors. In one approach, integrity constraints are described by assertions [Stonebraker74, Eswaran75].

1.2. The hierarchical model:

The hierarchical model represents classes of entities and hierarchical relationships among different entity classes. A class of **entities** is represented **as** a record **type**, and the hierarchical relationships are represented by a **tree structure**, with record types as nodes in the tree. The record type represents the attributes of a class of entities, while each record represents a particular entity of the class, and is composed of data items that describe the entity.

Each record is owned by only one record of the record type at **the level** above it in the tree, and can own in turn any number of records of the record types below it, if any. Many real world situations are naturally hierarchical, and are thus well represented by a hierarchical model. In

particular, individual **user** views, or **data** models, **are often** hierarchical. Databases used by **multiple** users often **need a more** complex model. In **the** hierarchical model, non-hierarchical relationships are represented in an awkward and non-symmetric fashion by defining **duplicate** record types and using pointers.

1.3. The network model:

The network **model** allows representation of non-hierarchical relationships among entity classes. A record **type** may **be owned** by more than **one record** type, leading to a network representation of relationships among **entity classes**. This permits a **direct** representation of m:n relationships among entity classes. **The** concept of a link-set between two record types is introduced. A link-set groups together records of **one record type, the member** record type, that are owned by a particular record of a different **record type, the owner** record type. Existence dependencies to govern **occurrences** of owner and member records of a link-set are specified by different types of link-sets, such as manual and automatic.

The database administrator may specify **the** access structure **used** for implementing a link-set as a chain of pointers, a pointer array, or **he** may specify that **the** records be stored **physically** adjacent. **Thus access** to the **records** in a particular link-set via the owner record **can** be very efficient. However, the database **designer** has to **recognize** and define the link-set and its access structure a priori, and **queries** based on structures not directly implemented may be quite costly to process.

A drawback of **the** network **model** is that only implemented relationships can be exploited, and that, due to implementation constraints, certain relationships are difficult to express (**such as** recursive sets [Taylor76], which are relationships **between records** of **the** same record **type**). Another criticism is that it is too implementation oriented, and thus provides limited data independence [Engles69].

1.4. Some other data models:

The problems with **the** relational, hierarchical and network models **have led** to active research in data models. Chang [Chang78] has developed an approach with a "database skeleton" which includes semantic information about **the** relationships between database relations, and defines **the** relationships **over a time** frame using **the** concept of **the** "state" of **the** database. The semantic information is **used** by **the** system in query translation, and incomplete **or** "fuzzy" queries may be processed. Manacher [Manacher75] differentiates relationships into several semantic categories. Abrial [Abrial74] **goes** further by distinguishing **every** relationship according to its particular semantic notion, but **states** that his model would be too complicated for database construction.

Chen [Chen76] has proposed a model **based on the** relational **model** which clearly distinguishes relations into two **types**: entities and relationships among **the** entities. Integrity rules for logical consistency are considered for **the** relation **types**, but are not part of **the** model. Schmid and Swenson [Schmid75] **develop the** semantics of the relational **model**, and show that, in the context of their model, relations in third normal form can **be** differentiated into **five** semantic types. Rules for insertion and **deletion** of tuples are given.

More recently, **models have been** introduced that provide a more detailed semantic description of the situation **being** modelled [Smith77, Hammar78, Navathe78]. In **these** papers, constructs are introduced to represent subsets of entity classes in **the** data **model**. **These** subsets have a semantic **significance** in the data **model**, such as certain identifying properties that make them different from other entities in the class,

The requirement to have a **model** which describes **the data relationships** independently of implementation concerns **was** recognized when standardization of the CODASYL model was suggested. The **ANSI/X3/SPARC** committee [Steel75] has described a DBMS architecture in **response** to **the** perceived long range **needs**. A principal component of the architecture is the conceptual schema, which is to contain essential information about the database itself. The conceptual **schema** would be augmented by an internal schema to define **the** implementation, and by **possibly** several external **schemas** to represent the transformations of the database to **the** views desired by the **users**.

2. PURPOSE OF THE STRUCTURAL MODEL

The numerous data **models presented** in the literature have given insight into the process of logical data model design, and the implemented relational, hierarchical and network database **systems** have provided experience on both logical and physical database design and implementation. The model presented **here** is intended to assist in the development of a conceptual data model **independent** of any implementation, but also to provide a framework for database implementation. We propose that the model **satisfies** the criteria [Kent77] for representing the relationships within the conceptual schema of a database system that has an architecture similar to the **ANSI/X3/SPARC** DBMS architecture.

The structural model which we present here:

- (1) avoids the storage structure dependency and the limitations of the **hierarchical** and network models,
- (2) introduces semantic information to **the** relational model by the representation of logical connections between relations which also define structural integrity constraint⁶ in **the** model itself,
- (3) allow⁶ a **precise** representation of the semantics of relationships between entity **classes**, and
- (4) provides a framework for **the design** of a database **system** starting with the **design** of individual users data models, to **the** integration of **the** data models to form a global **database** model, and finally **the** guidance of the **choice** of database implementation structures.

Associated with this structural model is a methodology to combine multiple, related data models to form an integrated database model, and to **design the data models** to match closely **the** real-world situation being represented. The individual data models also allow the user to specify some of his requirements of the database system.

The model we **present** is built from relations, augmented with two additional basic concepts. First we associate a relation **type** with **each** relation. Second we associate connection types with the relation types which **define the** structural integrity of this relation with respect to other relations that are logically related to it in **the** model. We **define** structural integrity to be the maintenance of a consistent relationship among tuples in different relations of the data model as defined by **the** connections among relations.

During the design and integration process, **the** relations will be manipulated. To **assure** manipulatability, we require all relations to be in Boyce-Codd normal form. However, it is not necessary to build the relations from the functional dependencies between attributes. Rather, as also argued by Chen [Chen76], if we first **define the** logical entities and **relationships** from the **real-world**, **then** simple transformations will **create** a model **where** all relations are in third normal form. **Once** a relation is **defined** with all its attributes, **one** can **check the** functional dependencies between **the** attributes of the relation. **If** a relation is not in third normal form, it **may** be transformed into two or more relations in third normal form [Wiederhold77, sec.7.2]. The structural model **prescribes** how **the** data model relation and connection types will represent the entities and relationships of a particular real-world situation, and hence limits the number of possible data **models** that **may** represent a real-world situation.

We **note** here that **the** structural **model** is completely independent of implementation considerations. While the structural model does represent connections between relations, it does not mandate implementation of **these connections**. Rather, the connections are used for definition of **some** logical integrity constraints. An implementation can be chosen based upon an existing relational, hierarchical or network database management system, or possibly by **using some** other approach.

3. THE STRUCTURAL MODEL

3.1, Real-World Structures:

A database **system** is used to model some aspect of the **real** world. **People** approach real-world data in several phases. First, **they** observe **the** situation and collect existing data that describe **the** situation. Then, from their observations, they classify the data into abstractions. Next, they **assess** the value of their abstractions in **terms** of how much it helps them manage the world with a minimum of exceptions. Finally, if **they have** to implement a system, they describe the real-world situation by a data model. Such a model may be **stored** on some physical medium (computer or paper files), and used as a guide for data processing. We hence introduce **a** model which can **be** used to represent the majority of real-world situations rather than a model which may **be used** to represent all **possible** real-world semantics.

The main building blocks of **the** data model are **classes of entities**, such as PEOPLE, CARS, HOUSES, . . . etc. An entity class is described by the primitive components that are used to describe **each** of its members, the **properties**. For **example**, the **entity** class CARS can have the properties **LICENSE-NUMBER, COLOR, MODEL, YEAR**. The properties that identify a specific entity within the entity class, in this case **the** single property **LICENSE-NUMBER**, are called the **ruling** properties. The properties that describe characteristics of an entity, in **this** case COLOR, MODEL, and **YEAR**, are called the dependent properties.

Associated with each property is a domain, the **set** of values the it can take in any of **the** entities that have this property. Some properties may be repeating. For example, consider the class of entities EMPLOYEES. One of the properties we may represent is **the** SALARY-HISTORY of an employee. Each **employee** will **have several** entries of the salary history, one for each salary **he** had during his previous employment period. The number of **entries** is variable from one employee to the next. The SALARY-HISTORY is also an example of a **compound** property, one which is formed of several, more basic, other properties. In this case, SALARY-HISTORY is formed from two **more** basic attributes, **YEAR** and SALARY-VALUE. However, such compound properties can always be decomposed into several **of** the basic properties,

We also have to **model** the relationships that exist between entity classes. A **relationship** is a mapping among classes. Thus, a relationship defines a **rule** associating an entity of one class with entities of other (not **necessarily** different) classes. Most relationships we encounter are between two entity classes. An example of such a **relationship** is CAR:OWNER between the **entity** classes CARS and PEOPLE. Such relationships may be 1:1 (for example **COUNTRY:PRESIDENT**), 1:N (for example **MANAGER:EMPLOYEE**), or M:N (for example **STUDENT: CLASS**). Other relationships may be among more than two **classes**. For example, **the** relationship **SUPPLIER:PART:PROJECT** is among three entity classes SUPPLIERS, PARTS, and PROJECTS.

A relationship between two **entity** classes has two important characteristics: the cardinality and the dependency. **The cardinality** of a relationship places constraints on the number of **entities** of one **class** that **can** be related to a single **entity** of the other class. The **dependency** characteristic of a relationship places constraints on whether an entity of one class **can** exist that is not related to any entities of **the** other class. We will discuss these characteristics **more** fully in section 4.1.

Finally, some **classes** of entities may **be** sub-classes of other entity classes. For example, the entity class EMPLOYEES is a sub-class of **the** entity class PEOPLE.

The data **model** should **reflect** the real-world structure as closely as possible. This makes it easier for the **users** to understand **the** model, and allows useful semantic information from **the real** world to **be** included in the data model.

In the structural model, relations are used to represent entity classes, and **some** types of **relationships** between entity classes. Other relationships between entity classes are represented by connections between relations. Relations will be categorized into several types, according to the structure they represent in a data model. Connections between relations will also be classified into **types**, and possible connections **between** relation **types** are a part of the model.

Simple properties are represented by attributes of relations. We will always decompose compound properties into **the simple** properties from which they are formed.

3.2. Relations and Connections:

Relational concepts are well known, but for conciseness we now define relation and relation schemes as we use them in the structural model. Then we formally define the concept of connections between **relations**.

In order to define a relation, we first **define** attributes, tuples of attributes, and relation schemes. Relation **schemas** specify the attributes of a relation. Attributes define the domain from which data elements that form the tuples of the relation can take values.

We will use **B, C, D**, to denote single attributes; **X, Y, Z**, to denote sets of **attributes; b, c, d**, to denote values of single attributes; and, **x, y, z**, to denote tuples of sets of attributes. For simplicity, we assume that all sets of attributes are ordered.

3.2.1. Relations:

Definition 1: An **attribute B** is a name associated with a set of values, **DOM(B)**. Hence, a **value b** of attribute B is an element of **DOM(B)**.

For an (ordered) set of attributes $Y = \langle B_1, \dots, B_m \rangle$, we will write **DOM(Y)** to denote $DOM(B_1) \times \dots \times DOM(B_m)$, where \times is the cross product operation. Hence, **DOM(Y) is the set $\{ \langle b_1, \dots, b_m \rangle \mid b_i \in DOM(B_i) \text{ for } i = 1, \dots, m \}$.**

Definition 2: A **tuple y** of a set of attributes $Y = \langle B_1, \dots, B_m \rangle$, is an element of **DOM(Y)**.

Definition 3: A **relation schema, R_s** , of order $m, m > 0$, is a set of attributes $Y = \langle B_1, \dots, B_m \rangle$. The **relation, R**, is an instance (or current value) of the relation schema R_s , and is a subset of **DOM(Y)**.

Each attribute in the set Y is required to have a unique name.

The set Y is partitioned into two subsets, K and G. The **ruling part, K**, of relation schema R_s is a set of attributes $K = \langle B_1, \dots, B_k \rangle, k \leq m$, such that every tuple y in R has a unique value for the tuple corresponding to the attribute set K. For **simplicity**, we assume the set K is the first k attributes of Y. The **dependent part, G**, of relation schema $R_s (= Y)$ is the set of attributes $G = Y - K$, where $-$ is the set difference operator.

All relations are in Boyce-Codd normal form. (For definitions of functional dependency and Boyce-Codd normal form, see section 8.1.)

We will write **R[Y]** or **R[B₁, . . . , B_m]** to denote that relation R is defined by the relation schema $Y = \langle B_1, \dots, B_m \rangle$.

Also, **K(Y)** will denote the ruling part of relation schema Y, and **G(Y)** will denote the dependent part. Similarly, for a tuple y in relation R, defined by the relation schema Y, **k(y)** will denote the tuple of values that correspond to the attributes K(Y) in y, and **g(y)** will denote the tuple of values that correspond to G(Y) in y.

A relation $R[Y]$ may have several attribute subsets Z which satisfy the uniqueness requirement for ruling part, In the structural model, the ruling part of a relation schema is defined according to the type of the relation (see sec. 3.4).

3.2.2. Connections:

We now define the concept of a connection between two relations, then define the types of connections that are used in the structural model, A connection is defined between two relation schemes, An instance of the connection exists between two tuples, one from each relation.

Definition 4: A *connection* between relation schemes X_1 and X_2 is established by two sets of *connecting* attributes Y_1 and Y_2 such that:

- a. $Y_1 \subseteq X_1$.
- b. $Y_2 \subseteq X_2$.
- c. $DOM(Y_1) = DOM(Y_2)$.

We then say that X_1 is connected to X_2 through (Y_1, Y_2) .

Two tuples, one from each relation, are *connected* when the values for the connecting attributes are the same in both tuples.

The definition of connection is symmetric with respect to X_1 and X_2 , and thus it is an unordered pair.

Connections may be more complex. For example, if we desire a connection between two sets of attributes with dissimilar, but related, domains, condition (c) above may be changed to $DOM(Y_1) = f(DOM(Y_2))$. The function f will relate values of data elements from the two domains. The equality condition in (c) above is the simplest case.

The structural model uses three basic types of connections, which we now define. Associated with each of the connection types are a set of integrity constraints that define the existence dependency of tuples in the two connected relations, These constraints define the conditions for the maintenance of the structural integrity of the model, We will define structural integrity, and discuss these constraints in section 3.5.

Definition 5: A *reference connection* from relation schema X_1 to relation schema X_2 through (Y_1, Y_2) is a connection between X_1 and X_2 through (Y_1, Y_2) such that:

- a. $Y_2 = K(X_2)$.
- b. $Y_1 \subseteq K(X_1)$, or $Y_1 \subseteq G(X_1)$, but Y_1 may not contain attributes from both $K(X_1)$ and $G(X_1)$.

Definition 5a: A reference is an *identity reference* if $Y_1 = K(X_1)$.

Definition 5b: A reference is a *direct reference* if it is not an identity reference.

Reference and direct reference are not defined symmetrically with respect to X_1 and X_2 , and thus are ordered pairs $\langle X_1, X_2 \rangle$ when the reference is from X_1 to X_2 . The identity reference is defined symmetrically, but we still consider it to be *ordered*. This is because identity references are used to represent a subrelation of a relation, defined in section 3.4.2, and we consider the reference to be directed *from* the subrelation to the relation.

Definition 6: An *ownership connection* from relation schema X_1 to relation schema X_2 through (Y_1, Y_2) is a connection between X_1 and X_2 through (Y_1, Y_2) such that:

- a. $Y_1 = K(X_1)$.

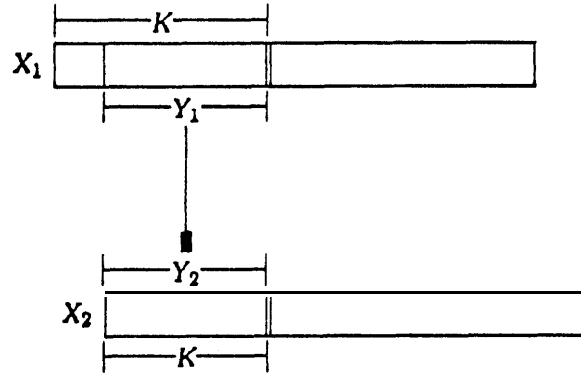

(a) Direct reference $\langle X_1, X_2 \rangle$ from the ruling part of X_1

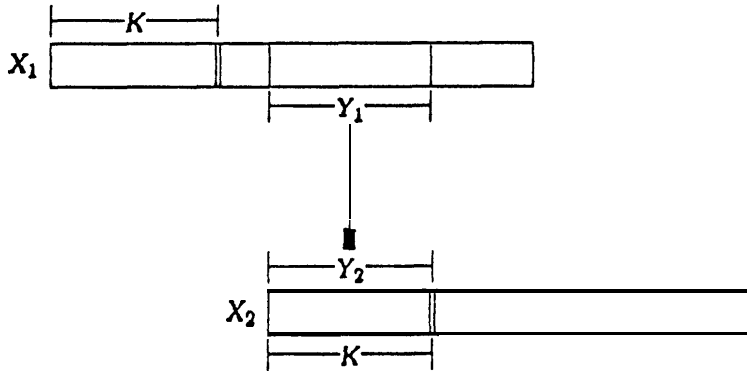

(b) Direct reference $\langle X_1, X_2 \rangle$ from the dependent part of X_1

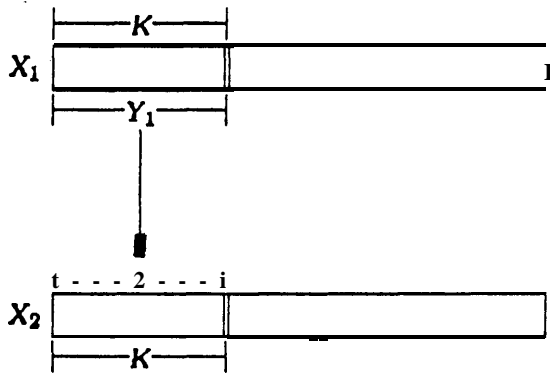

(c) Identity reference $\langle X_1, X_2 \rangle$

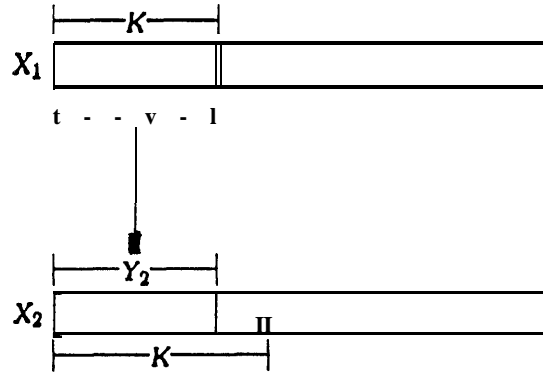

(d) Ownership connection $\langle X_1, X_2 \rangle$

Figure 1. Types of connections

b. $Y_2 \subset K(X_2)$.

The ownership connection is also non-symmetric with respect to X_1 and X_2 , and is an ordered pair $\langle X_1, X_2 \rangle$ when the ownership connection is from X_1 to X_2 .

The connections defined above may be represented graphically as in figure 1. They are represented by directed arcs, with the \blacksquare representing the to end of the connection. The ruling part attributes in each relation arc marked K , and separated from the dependent part attributes by double lines (\parallel).

3.3. Type8 of relations:

Relations in the structural model arc classified into structural types, which define their interaction with other relations in the data model. Relations can also be classified semantically according to the concept they represent from the real-world situation. One should be careful to distinguish between the semantic and **the** structural role of a relation in a data model,

Semantically, we distinguish between classes of entities, properties of classes of entities, and relationships among classes of entities. Classes of entities can be represented by several structural relation types, depending upon their relationship with other classes of entities. Hence, entity classes may **be** represented by either primary entity relations, referenced entity relations, or nest relations, as we shall see.

Non-repeating properties of a **class** of entities arc represented as attributes of the relation that represents **the** entity class. Repeating properties of a class of entities arc represented by a nest relation owned by the relation that represents the entity class (see section 3.3.3).

Relationships among entity classes can also **be** represented using different structures, **depending** upon the characteristics of **the** relationship. A relationship between two entity classes may be represented by an ownership connection, a reference connection, or two connections and **an** auxiliary relation. This auxiliary relation **may** be a primary relation, **a** nest relation, or an association relation (see section 4.1).

Structurally, relations arc categorized into five types: primary relations, referenced relations, nest relations, association relations, and lexicon relations. These **are** all relations which **have** the same form, but are classified according to their connections to other relations.

In this section, we informally present **the** rationale behind **the** choice of **the** different structural relation types. We give formal definitions for the relation types in section 3.4.

A relation in the data model which represents a class of entities in the real-world situation is termed an **entity relation**. The choice of entity classes is a fundamental aspect of the data model design **process**. The goal is to match entity relations as **closely** as possible to real-world entity **classes**.

Structurally, entity relations may be primary, referenced or nest relations. The choice of structural type to represent an entity relation depends upon its role in the data model. In the following three sections, we discuss the criteria for this choice.

3.3.1. Primary entity relations:

An important objective of the data model is to represent real-world entities. The existence of a tuple in the data model which represents such an entity is hence determined by the existence of the actual entity, independently **from** other modelling considerations. Classes of such entities arc represented in the data model by primary entity relations. Examples of primary entity relations are **EMPLOYEES** and **CARS**, 'Primary entity relations should **be** chosen to **be** update-independent of other relations in the data model. An update of another relation should not require an update of **a** primary entity relation. An update of an entity relation, however, may require updates to other relations connected to it, as we shall **see** later.

An example of **a** primary entity relation is **the** relation **EMPLOYEES** in a model that **rep-**resents a company. Updates to the **EMPLOYEES** relation occur only from outside the database. An employee tuple is inserted whenever a **new** employee is hired by the company, and deleted whenever an employee leaves. This potentially **affects** several other relations in the database such **as** **CHILDREN** and **EMPLOYEES-DEPARTMENT**. Thus, insertion of an employee tuple involves the possible addition of tuples to other relations in the database that arc connected to the employee relation, such as tuples that represent the employee's children in the **CHILDREN** relation, and tuples associating the employee with **the** departments **he** works for in the **EMPLOYEES-DEPARTMENT**

relation. Note that **the** number of additional tuples added to **the** database because of the insertion of a **new** primary entity tuple is variable, and determined externally; the model only presents the user with guidelines to follow when inserting a primary entity tuple.

The deletion of a tuple from a primary entity relation may imply the deletion of related tuples from other relations in the database. Thus, **the** deletion of an employee tuple will involve **the** deletion of tuples for his children from the **CHILDREN** relation, as **well** as tuples associating him with the department he worked in from the **EMPLOYEES-DEPARTMENT** relation. Such a deletion does not involve any additional checking before the tuple is deleted, since a primary entity relation may not be referenced by any other relation in the data model.

3.3.2. Referenced entity relations:

When representing a real-world situation, one often encounters abstractions that are used mainly to describe properties of other entities. Such entities are referenced by other entities in the model. This type of entity is a *referenced* entity, and classes of such entities are represented in **the** data model by referenced entity relations. Examples of referenced entity relations are **CAR MODEL SPECIFICATIONS**, referenced by the attribute **MODEL** in **the** relation **CARS**, and **JOB DESCRIPTION**, referenced by **the** **JOB** attribute of the relation **EMPLOYEES**. **The** use of **these** referenced entities greatly **reduces** redundancy in the data model. As we shall see, the main difference between a primary entity relation and a referenced entity relation in the structural model is in their update characteristics.

A **direct** reference connection will exist from **some** relations in **the** data model, termed the *referencing* relations, to **the** *referenced* entity relation. **The** reference connection restricts the **deletion** of tuples in the referenced entity relation, as **well** as **the** insertion of tuples in the referencing relations. We **discuss** these restrictions **here** in terms of an example, and will define them precisely in section 3.4.

An example of a referenced entity relation is presented with respect to a company database. Suppose the company wishes to keep track of current and possible suppliers for inventory items. The **SUPPLIERS** relation is a referenced entity relation. The existence of supplier tuples is **determined** by a selection from **the** real-world, since the company maintains a list of its current and possible suppliers. However, a supplier tuple may not **be** deleted while it is being referenced from the **INVENTORY** relation within the data model. Thus, **the** deletion of tuples from a referenced entity relation requires checking **the** tuples in all relations in the data model which reference this referenced entity relation. Addition of tuples to the referencing relation, **the** **INVENTORY** relation in **this** case, is restricted to those tuples that reference an already existing supplier, represented by a tuple in **the** **SUPPLIERS** relation in the database. Thus, the name of a supplier for a new inventory item should exist in **the** **SUPPLIERS** relation before **the** new referencing tuple is added to **the** **INVENTORY** relation.

Tuples of referenced entity relations may be referenced from **more** than **one** relation. For example, **the** **SUPPLIERS** relation, may **be** referenced from **the** **ACCOUNTS-PAYABLE** relation, describing unpaid bills, as **well** as from **the** **INVENTORY** relation. Note that supplier tuples may exist which are not currently referenced from other tuples in the database, but one **cannot** delete a supplier tuple without checking tuples in all relations that may reference the **SUPPLIERS** relation.

All other update characteristics for referenced entity relations are the same as the update characteristics for primary entity relations. In **the** rest of this paper, when we use the term entity relation without qualification, we will mean primary or referenced entity relation.

3.3.3. Nest relations:

Hierarchical dependencies occur frequently in real-world situations. Hence, real-world entities will be represented in the data model whose existence directly depends upon the existence of

another entity, For example, in a company database, the **CHILDREN** relation represents children of employees currently working in the company, The existence of children tuples in the Company database is justified while their parent works for the company, and the tuple representing the parent exists in the EMPLOYEES relation. Such entities will be represented in the data model by *nest relations*.

A nest relation always **corresponds** to a 1:N relationship **between** two data model relations, the *owner relation* and the *nest* relation, In our example, the EMPLOYEES relation is said to own the **CHILDREN** relation, This 1:N relationship is represented in the data model by an ownership connection from the owner relation to the *nest* relation.

For each tuple in the owner relation, a **set** of zero or **more** tuples will exist in the *nest* relation that are connected to this tuple. **The existence** of this set of tuples **depends** upon the existence of the *owner tuple* in the owner relation. The term 'nest relation' has been chosen because each owner tuple will own a 'nest' of tuples in the *nest* relation. **The existence** of individual tuples of the nest is determined by the real-world requirements.

Hierarchical dependencies also occur **when** a class of entities has a repeating property, where the number of **repetitions** is variable for each entity in the class. We then represent the repeating properties by attributes in a *nest* relation that is owned by the relation representing the entity **class**. An example is the education history attributes of an **employee** in the company database. Here, the EMPLOYEES relation owns the *nest* relation EDUCATION HISTORY. In the structural model, the normalization to first normal form forces the use of distinct *nest* relations, but the connection to the owner relation remains recognized.

Insertion of a tuple in a nest relation is contingent upon the existence of the owner tuple in the owner relation. Thus, **one** may not insert a child or an education history tuple without a corresponding **owner** employee tuple in the EMPLOYEES relation, **The deletion** of a tuple from a nest relation is not restricted by the ownership connection. The deletion of a tuple from the owner relation requires deletion of the *nest* of tuples owned by it in the *nest* relation. Insertion of tuples in the owner relation may involve the creation and insertion of a *nest* of tuples in the nest relation.

3.3.4. Lexicon Relations:

A *lexicon relation* is used to represent a one-to-one correspondence **between** two sets of attributes. Most frequently, the one-to-one correspondence will be **between** only two single attributes, but **sets** of attributes may also be involved. Examples are the one-to-one correspondence between the two attributes DEPARTMENT-NAME and DEPARTMENT-NUMBER in a company data model, or that **between** the two sets of attributes (**INSTRUCTOR, CLASS, SECTION**) and (**ROOM, HOUR, DAYS**) in a university data model. This one-to-one correspondence reflects a similar correspondence between properties.

Such one-to-one **correspondences** between two **sets** of attributes occur frequently, and **isolating** lexicons **simplifies** the data model considerably by transferring attributes that **serve the same** function into a lexicon relation. **One set** of attributes can **represent** all instances of either set outside of the *lexicon* itself. Which **set** of attributes remains in the core of the data model is left to the judgment of the model designer.

The lexicon relation will **have** a reference connection to it from **every** relation in the data model that includes **either one** or both of the **sets** of attributes in the lexicon. **The** reference connection may be a direct **reference** or an identity reference, depending on the situation.

Lexicons **serve** another important function in the data model, Frequently, relations will **have** more than one set of ruling (or *key*) attributes. A **set** of ruling attributes is guaranteed to have a unique value for any tuple in the relation, and thus any such **set** of ruling attributes may **be used** for tuple identification, In our model, each relation has one primary **set** of ruling attributes,

the ruling part of **the** relation. Other equivalent **sets** of ruling attributes are transferred to lexicon relations.

The use of lexicons can greatly **reduce the** number of **possible** alternatives for **the** data model, leading to a significant simplification of **the** model design process. The two sets of attributes in a lexicon relation can **be** treated conceptually **as** a single attribute in intermediate **processes** which lead to the design of the data model, and can thus be considered as equivalent **in** the data model. **Hence**, lexicon relations can **be seen** as a **means** of reducing **the** number **of** attributes in the **core** of **the** data model, leading to **the** creation of a clearer, simpler model,

3.3.5. Association relations:

We finally consider relations **used** to represent **the** interaction between two or more relations in **the** data model. Such relations will be **termed association relations**. An association relation between two relations associates with each tuple of **one** relation a number of tuples from the other relation (**possibly** none). **It** does not represent any existence dependency between **the** tuples in the different relations, **but** only an association **between** existing tuples.

An association relation of **order i** relates tuples from **i** owner relations. Each of the owner relations has an ownership connection to **the** association relation.

An example of an association of **order 2** is **the** relation EMPLOYEE-PROJECT which relates an employee to the projects **he** works in, and vice-versa. Each project tuple and each employee **tuple** have an existence of their own, independently from **the** tuples in **the** association relation. A tuple in the association only **relates** an employee with a project,

An example of an association of **order 3** is **the** SUPPLIER-PART-PROJECT relation, which relates tuples from three owner relations.

An association relation is **used** to represent information **relevant** to a relationship between entity **classes**. Usually, **the** entity classes are represented by the **i** independent **relations**. Thus, in **our** example, **the** EMPLOYEE-PROJECT association may include information **about the** job **the** employee **does** for the project, **the** percentage of **time** he works on the project, . . . etc. It is also possible for association relations to **have** no dependent information. **In** this **case** the association relation is **used** only for relating tuples from **the owner** relations together,

The update rules for an association **relation** and its owner relations are now self-evident: no tuple in the association relation may be created if there are **no** corresponding owner tuples in the owner relations, and deletion of a tuple from any **owner** relation **causes** the deletion of all tuples affiliated with it from **the** association. **Note** that **the** deletion **rule** does not affect the existence of the **tuples** related to the deleted tuple in the other owner **relations**: it only affects those tuples in **the** association relation that **serve to relate these** tuples together. Thus, deletion of an employee would not affect **the** existence of any of **the** projects he works for.

3.4. Formal definition of relation types:

In this section, we formally **define the** different **types** of relations discussed in section 3.3 in terms of their connections with other relation types in **the** data model. We **then** define **subrelations** of existing relations, and how a subrelation is connected to its base relation in section 3.4.2.

For the remainder of **the** paper, we will use the **term** relation for both the relation schema and **the** relation, since the meaning is clear from the context.

3.4.1. Basic relation types:

Semantically, relations are classified into entity and non-entity relations.

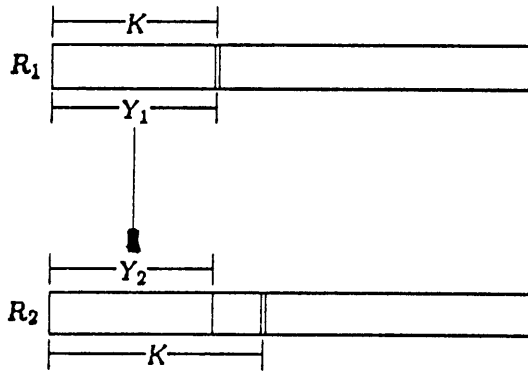

Figure 2. A nest relation, R_2

Definition 7: An *entity relation* is a relation $R[X]$ which defines a **correspondence** between members of a **class** of real-world entities and the tuples in $R[X]$.

The ruling part of an entity relation **defines** the correspondence to the **class** of real-world entities, while the dependent part includes the attributes that describe basic properties of the entities.

Structurally, we define five basic **types** of relations:

Definition 8: A *primary relation* is a relation that has no direct references or ownership connections to it from any other relation in the data model.

Primary relations are required to **have** no **references** or ownership connections to them. Thus, deletion of tuples from primary relations is unconstrained by the data model.

Definition 9: A *referenced relation* is a relation which has direct **references** to it from some relations in the data model.

The ruling part attributes $K(R)$ of a **referenced** relation, R , are **used** for referencing R from **other** relations. Hence, each relation R' that references R will have a set of referencing attributes that define the reference connection to R . This constrains insertion and deletion of tuples in both R and R' .

Insertion of a tuple in R should precede any reference to it **from** a tuple in a referencing relation. Deletion of a tuple from R involves checking that it is not referenced by any tuples from any of the relations that reference R . Insertion of a tuple in R' requires the existence of all tuples that it references.

Definition 10: A *nest relation* is a relation, R_2 , which has an ownership connection to it from exactly one other relation, R_1 , in the data model. R_1 is the *owner* of R_2 .

A **nest** relation R_2 has an ownership connection to it from the owner relation, R_1 . Hence, the ruling part $K(R_2)$ will consist of two parts: a **set** of attributes to define the connection with R_1 , and additional attribute(s) which must uniquely identify tuples owned by the **same** owner tuple in R_1 .

Insertion of tuples in R_2 requires the existence of the **owner** tuple in R_1 . Deletion of tuples from the **nest** relation may occur based on conditions determined externally from the database, but may also be the result of deleting an **owner** tuple from R_1 , which requires deletion of all tuples owned by it in R_2 .

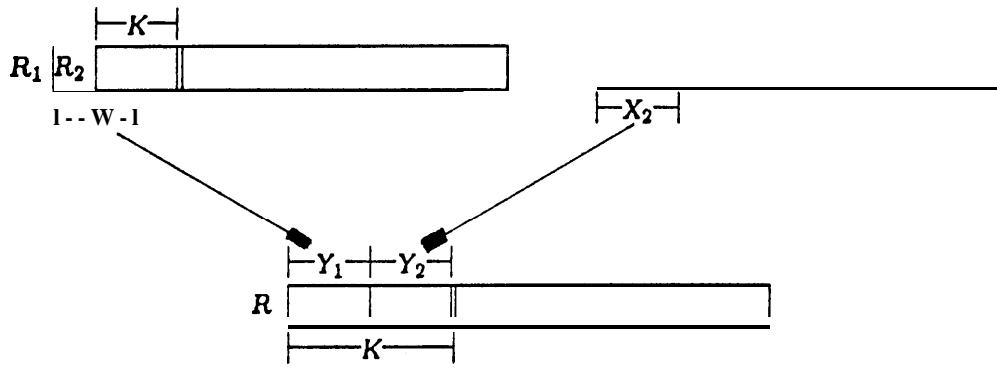

Figure 3. An association relation, R , of order 2

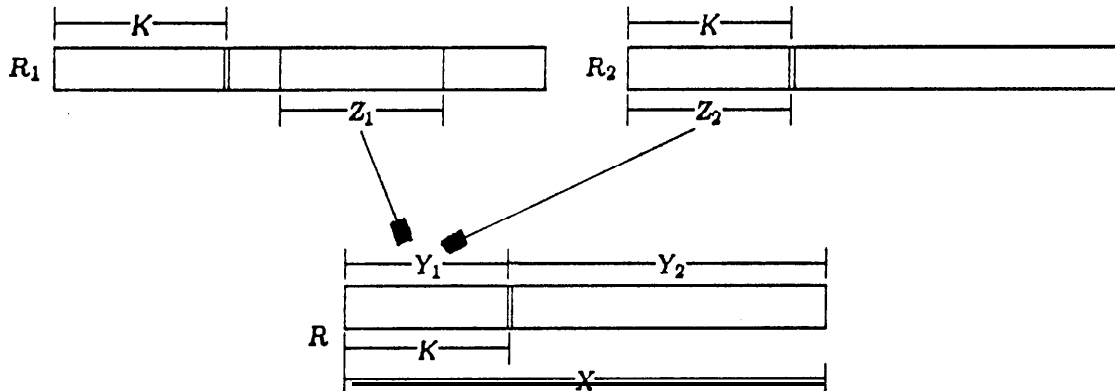

Figure 4. A lexicon relation, $R[X]$

Definition 11: An *association relation* R of order $i, i > 1$, is a relation R that has i ownership connections to it from i other relations in the data model, R_1, \dots, R_i such that:

- each R_j has an ownership connection to R through X_j, Y_j for $j = 1, \dots, i$.
- $Y_j \cap Y_k = \emptyset$ for $j \neq k$.
- $K(R) = Y_1 \cup \dots \cup Y_i$.

An association relation of order i has i ownership connections to it, one from each of the i owner relations. Hence, the domain of the ruling part attributes of an association relation is a **catenation** of i sets of attributes, each set defining the connection to one of the owner relations. A tuple in the association is owned by one tuple from each of the owner relation. For each tuple in an owner relation, there may exist zero, one OR many owned tuples in the association.

Deleting a tuple from an owner relation will thus require the deletion of all tuples owned by it in the association, Insertion of a tuple in the association will require the existence of the i owner tuples.

Definition 12: A *lexicon relation* $R[X]$ between two acts of attributes Y_1 and Y_2 defines a 1:1 correspondence between $DOM(Y_1)$ and $DOM(Y_2)$ such that:

- $Y_1 = K(X)$.
- the set of attributes Y_2 does not appear in any relation other than R .
- $Y_1 \cap Y_2 = \emptyset$, and $Y_1 \cup Y_2 = X$.
- R is referenced by one or more relations in the data model by identity or direct references.

A lexicon will **have** reference connections to it from all the relations in **the** data model that contain the set of attributes in **the** lexicon. **The** ruling part of a lexicon **is the** attribute set that **exists** in **the** other relations in the model, and **the** dependent part is **the** other attribute act in the lexicon. For example, if it is necessary to identify **the** department in **several** relations of the data model, then either DEPARTMENT-NUMBER or DEPARTMENT-NAME would be chosen. To simplify the model, an arbitrary single choice is made, say to use **the** attribute DEPARTMENT-NUMBER in all relations of the model. Then, DEPARTMENT-NUMBER will be the ruling part of **the** lexicon, and DEPARTMENT-NAME will **be the** dependent part. Every relation containing **the** attribute DEPARTMENT-NUMBER will **reference the** lexicon.

The above definitions **define the five** structural types of relations: primary, referenced, nest, association, and lexicon. Connections can exist at any **level** in the model: **nest** relations can be owned by other nest relations, by associations, or by referenced entity relations **as well as** by primary entity relations. Similar choices exist for referenced relations, associations, and lexicons. A subrelation may be **defined** on any relation. **In the** following section, we **define subrelations**.

3.4.2. Subrelation:

A subrelation S of **some relation** R **defines** a subset of **the** tuples in R **as** belonging to the **subrelation**. This subset of tuples either has a semantic significance in the data model, or has certain additional properties that **have to be** represented, but that are not represented in the other **tuples** in R . The relation R is **called the base relation** of **the** subrelation S .

We will not allow duplication of information in **the** representation of a subrelation, other than **the** information **needed** for tuple identification, **Hence**, a subrelation will have the **same** ruling part attributes **as** the **base** relation, and will be connected to **the** base relation through an identity reference connection. **The** identity **reference** reflects the fact that a tuple in **the** subrelation that has the **same** value for **the** ruling part as a tuple in **the base** relation represents the **same** entity in the data model.

All attributes other than **the** ruling part attributes of the **subrelation** have to **be** different from **the** attributes of **the base** relation.

Definition 13: A (non-restriction) *subrelation* of relation $R[X]$ is a relation $S[Z]$ such that:

- a. an identity **reference** exists from S to R .
- b. for **every** tuple z in S , **there** exists a corresponding tuple x in R such that $k(x) = k(z)$.
- c. $Z - K(Z) \cap X - K(X) = \emptyset$.

The relation R is **called the base relation** for subrelation S .

Definition 13a: A *restriction subrelation* of a relation $R[X]$, restricting the **set** of attributes Y , $Y \subseteq X$, to the subdomain D , $D \subseteq \text{DOM}(Y)$, is a subrelation $S[Z]$ of R such that: for every tuple x in R that has as **value** for **the set** of attributes Y a tuple y in D , there exists a corresponding tuple z in S such that $k(z) = k(x)$.

An example of a restriction **subrelation** is a relation TECHNICAL EMPLOYEES, a **subrelation** of the EMPLOYEES relation, restricting **the** attribute JOB of EMPLOYEES to **the** subdomain {engineer, researcher, technician}, say.

Existence of tuples in a restriction subrelation is totally dependent on the existing tuples in its **base** relation. **In** our example, **all employee** tuples with job **value** engineer, researcher or technician must also exist in the TECHNICAL EMPLOYEES **subrelation**, while all other employee tuples cannot exist in this subrelation.

An example of a non-restriction **subrelation** is a relation EMPLOYEES IN SPECIAL PROJECT X. Existence of tuples in this subrelation is determined externally of the data model, but confined to tuples in **the** base relation of all employees.

We will use subrelations to represent **three cases**:

- (1) When a subset of a relation has a semantic significance within the data model, or has additional attributes that **need** to be represented in the model.
- (2) When integrity constraints require a **subset** of a relation to own a nest relation or an association, or to **be** referenced from another relation.
- (3) When we combine data models to form an integrated database model (see section 5), **some** data models may represent **subsets** of relations represented in other data **models**. This has to be reflected in **the** integrated database model,

The update rules for **the base** relation and **the** subrelation are: when a tuple that belongs to the subset represented by the subrelation is inserted in (deleted from) the base relation, the corresponding tuple (having the **same** ruling part value) is inserted in (deleted from) **the subrelation**. Also, if an update to a tuple in **the base** relation results in the removal of the tuple from the **subset**, the corresponding tuple should **be** deleted from the subrelation. For example, if **the** job of an employee tuple is changed from engineer to manager the corresponding tuple **in** the TECHNICAL EMPLOYEES subrelation should be deleted.

3.5. Maintaining the structural integrity of the data model:

Structural integrity exists in our model when **the** tuples in the data model do not violate the constraints specified by **the** connections between relations. One **can** consider that the structural model contains a basic **set** of integrity assertions as part of **the** model. The integrity assertions are those **expressed** implicitly by **the** connections between relations, and are used to specify **the** existence dependencies, and hence the update constraints, of tuples in connected **relations**.

We do not specify in **the** model **when** or how **the** integrity constraints are to be maintained in an implementation of the data model. The purpose of the model is that integrity constraints can be recognized, and that implementors can refer for guidance to the model. In practical **implementations**, there may be intervals **where** the structural integrity rules do not hold. It should be known however which structural integrity constraints have **been** violated and are awaiting correction. Hierarchical and network databases tend to require that all integrity constraints be satisfied for those connections that are actually implemented. Techniques dealing with temporary integrity violations using artificial reference tuples are indicated in [Wiederhold77].

Our model may appear less powerful than the original relational model since update integrity violations **can** occur. In the pure relational model, inter-relation connections are not described, but are left to be discovered at query-processing time. **The** lack of recognition of **logical** connections between relations in a database model will simplify certain **technical** problems during update, but **does** not eliminate semantic inconsistencies relative to knowledge models of the database administrator or the **user**. Furthermore in many situations it is **best** to discover and correct integrity violations at the time of update rather than to try and cope with an inconsistent database at query **processing** time.

In section 3.5.1, we list the integrity constraints specified by each connection type, then give a summary of rules for maintenance of **the** structural integrity for each of the relation types. We then show in section 3.5.2 how **these** rules **may** be **expressed** as simple algorithms for maintaining the structural integrity of the database upon insertion and deletion of tuples, and update of attribute values.

3.5.1. Update constraints in **the structural** model:

The integrity constraints specified by **the** connection types are the following:

A **direct reference connection** from relation R_1 to relation R_2 specifies the **constraints**:

- (1) Every tuple in R_1 must **reference** an existing tuple in R_2 .

- (2) Deletion is restricted for tuples in R_2 . Only tuples that are not referenced from any relation in the data model may be deleted.

An *ownership connection* from relation R_1 to relation R_2 specifies the constraints:

- (1) Every tuple in R_2 must be owned by an existing tuple in R_1 .
 (2) Deletion of a tuple from R_1 requires deletion of all owned tuples in R_2 .

An *identity reference connection* from a subrelation R_1 to its base relation R specifies the constraints:

- (1) Every tuple in R_1 must reference an existing tuple in R .
 (2) Deletion of a tuple from R requires deletion of the referencing tuple in R_1 .
 (3) If R_1 is a restriction subrelation, then every tuple in R that belongs to the subrelation (specified by the value of the restricting attributes in R_1) must exist in R_1 .

We now give an informal listing of the update constraints associated with each relation type:

1. Primary relation:

- (a) The tuples are neither owned nor referenced by other tuples in the data model.
 (b) Deletion of a tuple requires the deletion of tuples owned by it in nest and association relations.
 (c) Insertion of a tuple requires the existence of referenced tuples in the relations referenced by attribute values in the new tuple.

2. Referenced relation:

- (a) The tuples are referenced from other tuples in the data model.
 (b) The ruling part defines the attributes through which the tuples are referenced by other tuples in the data model.
 (c) Deletion of a tuple is constrained by the existence of references to that tuple. Also, as in 1(b).
 (d) As in 1(c).

3. Nest relation:

- (a) The tuples may be referenced from other tuples in the data model.
 (b) The ruling part defines a specific owner tuple, and a specific tuple within the nest of tuples that has the same owner tuple.
 (c) As in 1(b). If the relation is referenced, deletion is constrained by existence of references to the tuple.
 (d) Insertion of a tuple requires the existence of the owner tuple in the owner relation, and the existence of referenced tuples in relations referenced by it.

4. Lexicon relation:

- (a) As in 2.a.
 (b) The ruling part is a set of attributes, through which the tuple is referenced.
 (c) Deletion of tuples is constrained by the existence of references to that tuple.
 (d) Insertion of a tuple requires no checking.

5. Association relation of order i :

- (a) As in 3.8.
 (b) The ruling part defines i specific owner tuples, one from each of the i owner relations.

- (c) A6 in 3.c.
- (d) Insertion of a tuple requires the existence of the owner tuples in the owner relation, and the existence of referenced tuples in relations referenced by it.

6. Subrelation:

- (a) A6 in 3.8.
- (b) The ruling part attributes are used for referencing the base relation through an identity reference.
- (c) A6 in 3.c.
- (d) Insertion and deletion of tuples in a restriction subrelation are totally controlled by existing tuples in the base relation.

As indicated earlier, a relation may have more than one connection with other relations in the data model. A nest relation may for instance itself be referenced, and may also reference tuples of another referenced entity relation. In these cases, all connections impose constraint6 on the data model.

3.5.2. Data model update algorithms:

We now give three simple algorithms for maintaining the structural integrity of the data model by observing the constraints given in the preceding section. The algorithms will be described in terms of the connection types defined in section 3.2.2.

3.5.2.1. Tuple insertion algorithm:

Upon receipt of a request to insert a new tuple x in relation R :

- a. Check the consistency of the new tuple with the current tuples in the database:
 - a.1. For every relation R_1 referenced by R through a reference connection, verify that the tuple y referenced by x exists in R_1 .
 - a.2. For every relation R_1 that has an ownership connection to R , verify that the owner tuple y of x exists in R_1 .
- b. If the new tuple is consistent with the data model, insert it and for every relation R_2 owned by R through an ownership connection, send a message to the user reminding him to insert the tuples owned by x in R_2 .

Thus insertion involves two actions: checking that tuples connected with the new tuple exist in the data model, and insertion of other tuples connected with the new tuple. The checking can be done automatically, but insertion of other new tuples will in most cases be done by the user. For example, the insertion of an employee tuple involves insertion of his children in a nest relation CHILDREN owned by the EMPLOYEES relation, and of the tuples associating the employee with the department he works for in the EMPLOYEE-DEPARTMENT association relation, also owned by EMPLOYEES. However, any new tuples in both CHILDREN and EMPLOYEE-DEPARTMENT are inserted by the user. The system only reminds the user that such data may exist, and if they do exist they should be added to the data model.

In some cases, when a nest relation represents repeating properties of an entity class, an application program can be written to insert all properties of the entity simultaneously. Both a tuple in the entity relation, and its nest of tuples that represent the repeating property are inserted.

3.5.2.2. Tuple deletion algorithm:

Upon receipt of a request to delete tuple x in relation R :

- a. Check for direct references to x from other tuples in the data modal: If relation \mathbf{R} is a referenced relation or a lexicon, check that x is not referenced by any tuple from a relation with a direct reference to \mathbf{R} . If x is referenced, send an error **message**, and do not complete the deletion,
- b. Check if tuples owned by x may **be deleted**: For every relation \mathbf{R}_1 owned by \mathbf{R} , initiate deletion of the tuples in \mathbf{R}_1 owned by x . For **every** subrelation \mathbf{R}_2 of \mathbf{R} , initiate deletion of the tuple y in the subrelation that corresponds to x .
- c. If all the owned and **subrelation** tuples can **be** deleted, complete deletion of x . Otherwise, do not complete deletion of x , and **send** a warning message that x could not be deleted,

Deletion also consists of two parts: checking that the tuple being deleted is not referenced, and deleting tuples owned by the tuple being deleted. The algorithm **is** recursively applied.

3.5.2.3. Attribute update algorithm:

Upon receipt of a request to update attribute A of tuple x , which belongs to relation \mathbf{R} :

- a. If A is neither an attribute through which \mathbf{R} references other relations, nor a member of the ruling part of \mathbf{R} , perform the update.
- b. Update of connection attributes:
 - b.1. Referencing attributes: If A is an attribute through which \mathbf{R} references a relation \mathbf{R}_1 , check that the new value will reference an existing tuple in \mathbf{R}_1 . If the new value references a non-existing tuple in \mathbf{R}_1 , do not complete the update and **send** an error message.
 - b.2. Ruling part attributes: **If** A is a member of the ruling part of \mathbf{R} , initiate deletion of x using the deletion algorithm. **If** deletion is completed, insert the updated tuple x_1 with the new value for A using the insert algorithm. Otherwise, send an error **message**.

4. REPRESENTATION OF DATA MODELS

We now present the guidelines that **the** structural model presents to a data model designer, and **discuss** how a choice is **made** between **the** different representation forms provided by the structural model to represent a particular situation. We will **see** that the same data can be represented with different relationships, according to the situation, or the view of the data model designer. Eventually such differences **can** be accommodated in the integrated database model.

We **use** the following notation to represent connections in our diagrams:

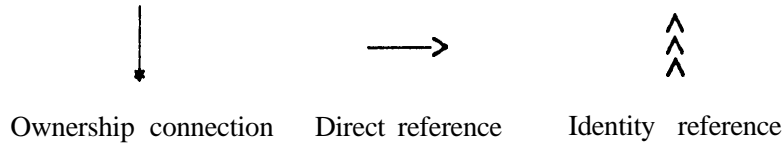

4.1. Representation of relationships in the structural model:

One of the advantages of **the** structural model is that it guides the choice of representation for a particular situation. **This** is because the **rules** attached to each relation and connection type are explicit, and will lead the data model designer to **carefully** consider the situation he is modelling. A model relevant to the real-world **situation** will be the result, and the situation will be clearly **represented**.

In the ensuing discussion, we use the **term** relationship to denote **a** relationship between two real-world entity **classes**, and the term connection to denote **a** connection between two relations in **a** data model.

Consider the relationship between two entity **classes**, **FATHERS** and **CHILDREN**. This is a **1:N** relationship, and may be represented using several different constructs in the structural model (figure 5):

- a. As an association between two entity relations representing fathers and children.
- b. As a direct reference, from an entity relation representing children, to a referenced entity relation representing fathers.
- c. As an ownership connection, from an entity relation representing **fathers**, to **a nest** entity relation representing children.

The choice among **these** alternatives depends upon **the** situation being modelled.

First, consider the case **where** the data model represents a community of people. Each person in the community has an identity of his own, and we want to represent the father-child relationship between two persons in **the** community. In this **case**, **the** appropriate representation would be **as** an **association** between two persons, **the** FATHER-CHILD association relation (figure 5a). If either the father or his offspring move from **the** community, there is **no** further need for a father-child connection between two persons in the community. This is **well** represented in the data model by the association, since deletion of a father (or child) tuple **causes** the deletion of the associating tuple, but **leaves** the tuple representing the other person unaffected.

On the other hand, **suppose** the data model represents data from a school system. In this **case**, the father-child relationship is **best** represented by a reference connection from **a** CHILDREN relation to **a** FATHERS relation (figure 5b). This restricts the deletion of a father tuple **as** long as it is being referenced by a child tuple. Again, this is a faithful representation of the situation **since** we want to keep information on the father **as** long as he has a child in the **school**. Also, every

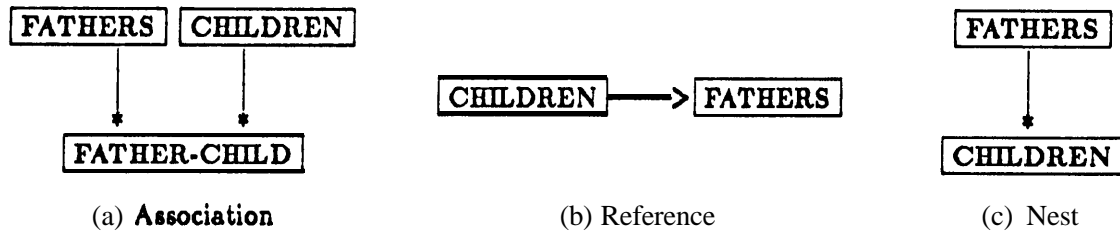

Figure 5. Some representations of the **FATHER:CHILD** relationship

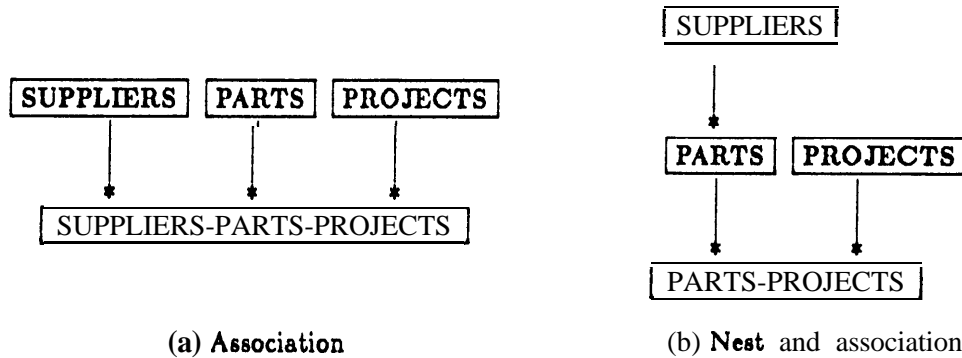

Figure 6. Some representations of the **SUPPLIERS:PARTS:PROJECTS** relationship

child in this school must have **some** information about his father. (If the father is unknown, an “unknown father” tuple could be **placed** within the FATHERS relation.)

Finally, if the data model represents data from a **company**, and a child is represented in the data model only because his father works for **the** company, then the relationship is best represented as a nest relation CHILDREN owned by **the** FATHERS relation (figure 5c). (In this **case**, FATHERS could be a subrelation of **the** EMPLOYEES relation.) Then, children are automatically deleted from the data model once their father is deleted. Here, when an employee is fired (and the decision is made to remove his representation from the active employees file), the company is not interested in any information about his children.

Let us consider a second example, that of an inventory allocation. The situation being represented is the association **between** suppliers, parts and projects, **if each** of the three entity classes has an independent existence of its own, **the** appropriate representation is an association among three entity relations SUPPLIERS, PARTS and PROJECTS (figure 6a).

Alternatively, suppose that we want to associate with **each** supplier the part that he supplies, so that a part **does** not have an independent existence, but depends on **the** supplier that supplies the part. Then, the situation is **best** represented by two entity relations, SUPPLIERS and PROJECTS, a nest entity relation PARTS owned by the SUPPLIERS relation, and an association relation PARTS-PROJECTS between PARTS and PROJECTS (figure 6b). Note that this represents the full association of **SUPPLIER:PART:PROJECT**, since by the definition of a nest relation, the ruling part of the nest relation PARTS includes the ruling part of the SUPPLIERS relation (**see** section 3.4.1).

These two examples show how the update rules **associated** with each relation type are used for guidance when designing a data model. The update rules force the data model designer to carefully consider the characteristics of the situation that he is modeling, and thus the data model becomes a faithful representation of the situation.

4.2. Representation of a relationship between two entity classes:

In this section, we consider all possible ways in which the structural model can represent a relationship between two entity classes. This is important for identifying the constraints on relationships. It is also important when we discuss data model integration in section 5.

Consider two entity classes, A and B, related in some way. One characteristic of the relationship is its **cardinality**. The cardinality of the relationship restricts the number of entities of one class that may be related to an entity of the other class. The cardinality of the relationship between A and B may be:

- (a) **1:1**, an entity in A may be related to at most one entity in B, and vice versa.
- (b) **1:N**, an entity in A may be related to N entities in B, $N \geq 0$, but an entity in B may be related to at most one entity in A.
- (c) **M:N**, an entity in A may be related to N entities in B, $N \geq 0$, and an entity in B may be related to M entities in A, $M \geq 0$.

Cardinalities may be further constrained by specifying M and N as constant numbers. For example, a 1:1 relationship is a constrained 1:N relationship with N set to 1.

The second characteristic of relationships is the **dependency**. The dependency specifies whether an entity of one class can exist independently, or whether it must be related to an existing entity of the other class. Dependencies can be classified into three types:

- (a) A **total dependency** specifies that entities in both classes must be related to a specified number of entities of the other class at all times.
- (b) A **partial dependency** specifies that entities from one class, entity class A say, must be related to a specified number of entities of the other class, B here, but that entities in B can exist independently.
- (c) A **no dependency** specifies no dependency constraints.

A direct relationship between the two entity classes A and B may be represented in the structural model as one of five choices (figure 7):

- (1) A reference connection: entity class A is represented as a relation R_a , referencing the relation R_b that represents entity class B (figure 7a). The cardinality of the relationship A:B is $N:1$, $N \geq 0$, and the dependency is partial of A on B (each entity in A must be related to exactly one entity in B).
- (2) An ownership connection: entity class A is represented by a relation R_a that owns a nest relation R_b representing entity class B (figure 7b). The cardinality of the relationship A:B is $1:N$, $N \geq 0$, and the dependency is partial of B on A (each entity in B must be related to exactly one entity in A).
- (3) An association relation: relations R_a and R_b represent entity classes A and B, and an association relation R_{ab} represents the relationship (figure 7c). The cardinality of the relationship A:B is $M:N$, $M \geq 0$, $N \geq 0$, and there is no dependency.
- (4) A nest of references: relations R_a and R_b represent the entity classes A and B. A nest relation R_{ab} owned by R_a , and a reference connection from R_{ab} to R_b represent the relationship (figure 7d). The cardinality of A:B is $M:N$, $M \geq 0$, $N \geq 0$, and there is no dependency.
- (5) A primary relation and two reference connections: relations R_a and R_b represent the entity classes, and the relationship is represented by a primary relation R_{ab} and two reference connections from R_{ab} to R_a and R_b (figure 7e). The cardinality of A:B is $M:N$, $M \geq 0$, $N \geq 0$, and there is no dependency.

Other relationships may exist indirectly. For example, if entity classes A and B, and entity classes B and C are directly related, an indirect relationship exists between entity classes A and C. We will only further consider direct relationships in this report.

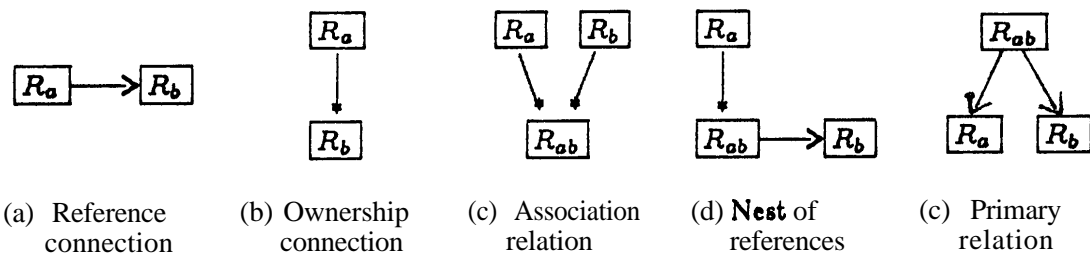

Figure 7. Representing two directly related entity classes

Data models that represent the same two related entity classes may use different representations for the relationship according to the way they view the update constraints. Two reasons for choosing different representations can be distinguished: difference in understanding and difference in representation. We illustrate the differences with an example.

- (1) The two data models differ in their understanding of the same real-world situation, Consider the two entity classes DEPARTMENTS and EMPLOYEES. It is possible that one user assumes that the relationship between DEPARTMENTS and EMPLOYEES is $1:N$ (each employee works in only one department). A second user is aware of exceptions and considers the relationship $M:N$ (an employee may work in more than one department). A disagreement exists here about the actual situation being modeled, and one of the data models is in error. It may be that the first user knows only about employees that work in one department. If such a conflict occurs between the two data models, the real-world situation being modeled must be re-examined to determine its actual characteristic. We will not consider this problem further.
- (2) The two data models represent the real-world situation differently, each user choosing the representation which best suits his integrity control requirements. Consider the DEPARTMENTS and EMPLOYEES example, and suppose the relationship is of cardinality $1:N$. It may be represented in one of the following ways, among others:
 - (a) a reference connection from EMPLOYEES to DEPARTMENTS (figure 8a),
 - (b) an ownership connection from DEPARTMENTS to EMPLOYEES (figure 8b,8c),
 - (c) an association relation restricted to $1:N$ (figure 8d),
 - (d) a nest of references from EMPLOYEES to DEPARTMENTS (figure 8e).

The different representations reflect different integrity requirements:

The reference representation requires each employee represented in the data model to belong to a department, and restricts deletion of a department from the data model while it is referenced by some employee,

The ownership connection representation also requires that each employee belongs to a department, but that deletion of a department tuple from the data model results in the deletion of all the employee tuples who work in that department.

The association does not place any constraints on the existence of the actual entities represented, the employee and department tuples. However, an association can exist only between tuples represented in the data model.

Finally, the nest of references restricts the deletion of a department while referenced by some employee, but allows employee tuples to exist in the data model that are not related to any department.



(a) Reference connection

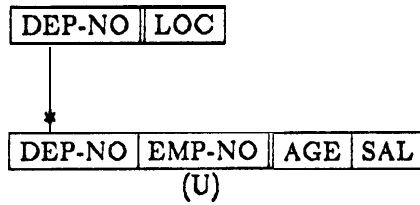

(b) Nest with unique employee identification

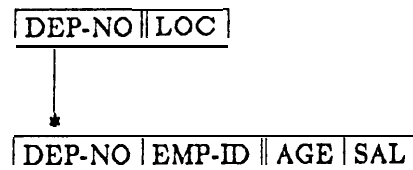

(c) Nest with non-unique employee identification

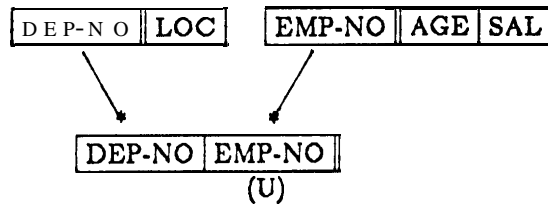

(d) Association

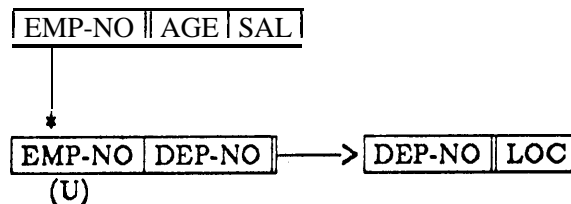

(e) Nest of references

Figure 8. Different representations of the **DEP:EMP 1:N** relationship

Since the association representation **can be used** to represent $M:N$ relationships, but **here** the DEP:EMP relationship is $1:N$, the EMP-NO attribute must have a unique value for each tuple in **the** association relation, This is indicated in figure 8d by marking the attribute with a (U). **Note** that this does not violate Boyce-Codd normal form.

The nest of references may also represent an $M:N$ relationship, and to restrict it to $1:N$, we also mark the **EMP-NO** attribute in the connecting **nest** relation by a (U) (figure 8e). We will use **this** convention throughout the examples in section 5.

In the ownership connection representation, we must consider two cases. The identifying attribute for each EMP tuple in figure 8b is **EMP-NO**, and has unique values for **each** employee independent of his department. Hence, we mark it (U). In figure 8c, the identifying attributes for an EMP tuple are the two attributes DEP-NO and **EMP-ID**, where **EMP-ID** serves to define the employee within his department, and **hence** is unique within a department but is not unique **over** all employees.

The different views **may** all be equally valid, and **hence more** than one set of views, and **corresponding** semantics, has to **be** retained in the integrated database model **so** that it **can serve** in a variety of situations.

We now consider the problem of integrating different data models, defined by independent user groups and applications, into an integrated database model, to be used **as** the conceptual schema. We assume a database system architecture similar to that described by the **ANSI/X3/SPARC** report.

5. INTEGRATION OF DATA MODELS

We now discuss integration of data **models**. First we briefly define our terminology for logical database design.

A **DATA MODEL** is a representation of the requirements of a particular potential database **user** group or application. The definition of data models for individual user groups that expect to use the database is the first step in the design of an integrated database.

The **DATABASE MODEL** is the integrated model created by merging the individual data models. During merging, differences in **view** are bound to appear. The differences may be resolved by transformations of the original data models. **It** is possible that unresolvable conflicts will emerge among the original data models. Then management **decisions** have to **be** made to force data model changes, or to abandon the integration with respect to **some** data models.

A **DATABASE SUBMODEL** is **the user** or application view that is consistent with the integrated **database** model. Hence, if no **conflicts** occurred between a **user** data model and the integrated database model, the database submodel for that **user** will **be the same** as the data model. If some conflict had arisen, some differences will exist **between** the data model and the database **submodel**.

In section 5.1 we consider **some** general concepts of data model integration, and in section 5.2 we consider the integration of **relations from** different data models that represent the same real-world entity class. In section 5.3 we show how to integrate two different representations of a relationship between the same two real-world entity classes.

5.1. Concepts of integration:

The data models we integrate will represent real-world situations that partially overlap, otherwise there will **be** no need for integration. **Hence** we expect to discover relations in separate data models that represent the **same** entity classes. The first phase of integration is to recognize **such** relations. This is not always a simple task, since different data models may use different names for relations that represent the **same** entity class.

Recognition of relations that represent the **same** entity class in different data models is based on matching ruling parts, since **the** ruling part defines **the** correspondence to an entity class. **The** relation names and the ruling part attribute names can provide an initial hint to such **correspondences**. **If** data exists, similar values within the ruling part attributes can further indicate candidates for entity matching. A match or overlap of the domain definition of ruling part attributes **can** establish **the** necessary equivalence.

Ruling parts may **be** translated via lexicons, **so** the search for similar ruling parts must also consider lexicons of ruling parts in the data models. Since lexicons preserve the identity of ruling parts, we will not specify throughout that lexicons can **be used** in the matching of ruling parts. **Some** examples of equivalence through lexicons will **be** given in section 5.2.

We assume in this report that rigorous definitions exist for the domains that the attributes cover. Definition of domains and attribute encoding can **be** a major effort, but is outside the scope of this report. This problem is also addressed by **people** working *on* the requirements analysis phase of database design.

The second phase of integration, following the recognition of relations that represent the same entity **classes**, is the recognition of differences in the representations. These differences are of three types:

- (1) Representation of different properties of the **same** entity class. **This is** reflected in different dependent part attributes in the relations that represent the **same** entity **class**.

- (2) Representation of different subsets of entities of the same entity class. **This** is reflected in different tuples in the relations that represent the same entity class,
- (3) A combination of (1) and (2).

We will cover integration of those **cases** in section 5.2.

The final phase is to integrate **the** representation of relationships between two entity classes. As shown in section 4.2, there are five ways to represent direct relationships in the structural model. Data models may choose to represent the relationship between the same two entity classes differently, according to their view of the situation. Hence, the final phase of integration is to create an integrated database model which will support different representations of relationships in the data models. We **cover** this phase in section 5.3.

Many data models may have to **be** integrated into a single database model. To avoid excessive complexity we will analyze the integration of only two data models in detail. Successive integration steps can merge another data model with the database model being built, creating a new database model. Since both data models and database models use the same primitives, this should not pose a problem.

We hence have two data models, data model 1 (dml) and data model 2 (dm2). Both data models will include relations that represent some common entity classes, **as well** as other classes of data. We only look at one entity class A in section 5.2, and two **entity** classes A and B with a relationship **between them** in section 5.3. We will denote the relations that represent entity classes A and B in dml and dm2 by R_a and R_b . If both representations are the same, clearly there is no **need** for any transformation, and the integrated database model (idbm) will use the **same** representation. If representations differ, we create an idbm to support both data models.

The idbm will then support database **submodel 1** (dbsml) and database submodel 2 (**dbsm2**), corresponding to dml and dm2 respectively. In most **cases**, dml and dm2 will not **be** changed, so dbsml and **dbsm2** will **be** equivalent to dml and **dm2**. In **some cases**, where conflicts appear, **one** of the data models may have to be changed, and **the** corresponding database submodel will reflect those changes. When the database model is established, it may also be desirable for pragmatic reasons to change a database submodel to achieve a better agreement with **the** database.

In **some cases**, only a subset of the tuples in relation R_a (or R_b) in the idbm correspond to the R_a (or R_b) relation included in dbsml or **dbsm2**. We then use a subrelation to represent the subset, and an identity connection will join it to R_a in **the** idbm. For example, if R_a in dbsml corresponds to a subrelation of R_a in **the** idbm, we denote this subrelation by R_{a1} in the idbm, and R_{a1} will have an identity reference to R_a . This subrelation R_{a1} of R_a contains only the ruling part attributes of R_a , so that no duplication of information occurs in the idbm. All other attributes in R_a can **be** accessed through the identity reference to R_a .

We do not address the problem of authorization of users to perform insertion and deletion. We assume that every **database** submodel has complete insert, delete, and update authorization **over** the part of the database model it represents. Hence, if one submodel, dbsml say, inserts a tuple that does not violate **the** integrity constraints of **dbsm2**, the tuple is inserted in both of them. **If** the tuple violates **the** integrity constraints of **dbsm2**, it is inserted but remains invisible to **dbsm2**. For deletion, if deletion of a tuple is legal in dbsml, say, but the tuple may not **be** deleted in **dbsm2** because of integrity constraints, **the** tuple will be kept in the idbm and in **dbsm2**, but will **become** invisible to dbsml.

After integration, dbsml and **dbsm2** are both supported by the idbm. A mapping will exist from each submodel to **the** idbm. This mapping includes additional integrity rules, derived from the integration process, which will apply to the idbm. **These** rules are enforced when a database submodel performs an insertion, deletion, or update. We will list these additional rules with each **case** of integration.

5.2. Integration of different representations of entity classes:

5.2.1. Recognition of **relations** that represent the **same** entity class:

This phase of integration requires **the** recognition of relations included in different data models that represent **the same** entity class. Knowledge of **the** real-world situations being modelled is helpful to match relations that represent the **same** entity class but have different **names** for relations and ruling part attributes. **The** domain definitions of ruling part attributes will **then** verify **the** equivalence of such relations by their partial overlap or total match.

Some models may include lexicons of ruling parts for **some** of the relations in the model. Examination of such lexicons is necessary when matching ruling parts. For example, dm1 may include a relation EMPLOYEES that contains the attributes (EMP-JVA ME, ADDRESS, **HOME-PHONE**, OFFICE, **OFFICE-PHONE**, **DEPT**), representing a directory of **the** employees. Data model 2, representing job information, includes a relation EMP that contains **the attributes** (**EMP-NUMBER**, **AGE**, **JOB**, SALARY, **DEPT**), and a lexicon relation (**EMP-NUMBER**, **EMP-NAME**) (figure 9a). To recognize that both relations represent **the same** entity class of EMPLOYEES, **the** integrators must consider both the **EMP-NUMBER** and **EMP-NAME** attributes from **the** lexicon relation in dm2 when matching the ruling part of the EMP relation to the ruling part of **the** EMPLOYEES relation.

5.2.2. Integration **of relations** that contain different attributes:

We first consider **the** case where one representation dominates **the** other. **Here**, dm1 includes a relation **R₁**, and dm2 includes a relation **R₂** that represents **the same** entity class as **R₁**, and contains all **the** attributes represented in **R₁**, plus **some** additional dependent part attributes. **The** idbm will include a relation **R** that contains **the set** of attributes represented in **R₁**, and a subrelation **R'** of **R** that contains **the** dependent part attributes represented in **R₂** but not in **R₁**. **The** tuples in **R** correspond to **the R₁** tuples in dbm1, while the subset of tuples in **R'** will correspond to the **R₂** tuples in dbm2. **When** dbm1 inserts a tuple, it is only inserted in **R**, **since it does** not contain **the** dependent part attributes of **R'**. **The** tuple is only visible to dbm1. **When** dbm2 inserts a tuple, it is inserted in both **R** and **R'**, since it contains the dependent part attributes of both **R** and **R'**. **Hence**, **the** tuple is visible to dbm1 also.

The general **case** is that neither relation **R₁** of dm1 nor relation **R₂** of dm2 contains **the** complete **set** of attributes, but each contains a **set** of attributes common to both models, and a set of dependent part attributes unique to its model. In this case, we must create two **subrelations**. An example is shown in figure 9. Relation **R** represents **the common** attributes, and two subrelations **R₁** and **R₂** are **used** to represent **the** tuples in dbm1 and dbm2 respectively. **When** dbm1 inserts an employee tuple, it is inserted in **R** and **R₁**, but is invisible to **dbm2**. **When** dbm2 inserts **the** tuple with **the same** ruling part value, the tuple is also inserted in **R₂**, and becomes visible to dbm2. A check has to **be** performed to **ensure** that common attributes have **the same** values. Thus, the **base** relation **R** insures the integrity of data values that are common to both data models.

The lexicon relation only references **R₂**, since it is only represented in dbm2.

If **the** two data models use different ruling part attributes, and neither represents **the** ruling part attributes in **the** other data model (for example, if in figure 11a dm2 did not include **the** lexicon), **then** two solutions exist. The first solution is to change **one** of **the** data models to include the ruling part attributes of **the** other data model. The second solution, which involves **the** database administrator, is to **create** a lexicon in the idbm in which every **new** tuple is included **before** its insertion by **either** data model.

We are only dealing with **the** data model here. When actual databases are to **be** integrated, inconsistencies may exist in the data. For example, the **same** employee may have his department

relation R_1 (EMPLOYEES)

EMP-NAME	ADDRESS-I	HOME-PHONE	OFFICE	OFFICE-PHONE	DEP-NO
----------	-----------	------------	--------	--------------	--------

DM1 (directory of employees)

relation R_2 (EMP)

(lexicon)

EMP-NO	AGE	JOB	SAL	DEP-NO
--------	-----	-----	-----	--------

EMP-NO	EMP-NAME
--------	----------

DM2 (job information)

(a) Lexicon of a ruling part that must be considered

relation R	subrelation R_2 (subset in DBSM2)
EMP-NAME DEP-NO	EMP-NAME AGE JOB SAL

^
^

subrelation R_1 (subset in DBSM1)

EMP-NAME	ADDRESS	HOME-PHONE	OFFICE	OFFICE-PHONE
----------	---------	------------	--------	--------------

(lexicon, visible to DBSM2 only)

EMP-NAME	EMP-NO
----------	--------

(b) Integrated database model

Figure 9. Integration of different sets of attributes (with lexicon)

listed as 'foundry' in one data model, and as 'management' in another. This problem is a post design issue, although we note that the structural model would not allow this inconsistency if the different submodels insert their tuples representing **thesame** employee at different times.

We also note that although many subrelations may exist for the **same base** relation in the integrated database model, this is only at the model level. At the implementation level, the base relation and all its subrelations may be placed in the same file, with a conditional field for each subrelation in each record to indicate whether the record is in the subrelation or not. It may also be worthwhile to change database submodels by making them aware of a few additional attributes to simplify the database model.

5.2.3. Integration of relations that represent different sets of tuples:

We now consider the case where there are differences in the selection of entities to be represented. For example, if one data model, dml, includes a relation R_1 , and dm2 includes a relation R_2 that represents a subset of the tuples in R_1 . The idbm will then include a relation R and a subrelation R_2 of R to represent the tuples in R_2 of dbsm2. The subrelation R_2 may be a restriction subrelation if the subset of tuples in R_2 is determined by attribute values in R , or a non-restriction subrelation if the subset of tuples in R_2 is determined externally, independent of the model.

For example, dml (for the payroll department) may represent all employees of a company in an EMPLOYEES relation, while dm2 (for the sales department of the company) includes the relation SALES FORCE, the employees that work in the sales department. The idbm then includes a relation EMPLOYEES, and a subrelation SALES FORCE of EMPLOYEES. If the EMPLOYEES relation contains a DEPARTMENT attribute, the subrelation SALES FORCE is a restriction subrelation on the DEPARTMENT attribute, restricting the attribute to the value sales. If EMPLOYEES does not contain a DEPARTMENT attribute, SALES FORCE would be a non-restriction subrelation. In either case, after integration, dbsm2 is only allowed access to tuples in the SALES FORCE subrelation, but could still access their attribute values from the base relation EMPLOYEES, while dbsm1 would be allowed access to all employee tuples.

The general case is that the tuples in the two relations partially overlap each other. Then dm1 includes relation R_1 and dm2 includes relation R_2 that represent the same entity class, such that the tuples in the two relations obey the constraints $R_1 \cap R_2 \neq \emptyset$, $R_1 - R_2 \neq \emptyset$, and $R_2 - R_1 \neq \emptyset$.

The idbm then includes a relation $R = R_1 \cup R_2$, and two subrelations of R , R_1 and R_2 . Again, R_1 or R_2 could be either restriction or non-restriction subrelations. For example, referring to a university database, dm1 (representing the computer science department of the university) includes a relation CSD PROFESSORS, and dm2 (representing information about permanent faculty) includes a relation TENURED PROFESSORS. The idbm then includes a relation PROFESSORS, and two subrelations of PROFESSORS, CSD PROFESSORS and TENURED PROFESSORS. Each database submodel is allowed access to his subset, and the base relation assures the integrity of common data represented in both models,

In the last example, it is possible that the relation in each data model contains attributes common to both relations, and a set of its own attributes. Then, the base relation in the idbm will contain the common attributes, and each subrelation will contain its own additional set of attributes,

5.3. Integration of different representations of relationships:

In the following sections (5.3.1-5.3.4), we assume that we have two data models, dm1 and dm2, and that both data models represent two entity classes A and B, and a relationship between them. R_a and R_b will denote the relations that represent entity classes A and B. If the representation of the relationship between A and B involves an auxiliary relation (association, primary or nest relation) we will designate it R_{ab} .

There are five ways of representing a relationship between two entity classes in the structural model (section 4.2). Three of these representations are not symmetric with respect to A and B (reference, nest, nest of references), and two are symmetric (association, primary). If we consider all possible combinations without looking at symmetries, the set of possible cases for combining different representations pairwise is $2 \times (5 + 4 + 3 + 2 + 1) = 30$. We remove 5 cases where the representation is identical in both data models, and $(5 + 4)$ cases because the association and primary cases are symmetric with respect to R_a and R_b . Then 18 cases remain to be considered. We consider all possible combinations with the association representation first (4 cases) in section 5.1.1. We then consider the cases that remain with nest of references (8 cases, section 5.1.2), with references (4 cases, section 5.1.3), and with nest (2 cases, section 5.1.4).

5.3.1. Integration with an association:

In this section, we consider integration of an association with other representations of a relationship. In those cases, dm1 represents the relationship A:B as an association relation, and dm2 will use a different representation. The association may represent a relationship of cardinality $M:N$. Our assumption (section 4.2) that both original data models accurately represent the same situation implies that the cardinality of both representations is the same. Hence, the cardinality of the relationship is restricted to the representation in dm2.

In order to demonstrate how two different data models may be integrated, we will present the integration of an association with the nest of references (figure 10a).

In this case, the only difference is that dm1 can freely delete tuples from R_b , while in dm2 deletion is restricted by referencing tuples from R_{ab} . Hence, we create two subrelations, R_{b1} and R_{ab1} . Those subrelations represent the tuples in R_b (and R_{ab}) of dbms1. Tuples in R_b and R_{ab} in the idbm may include some tuples deleted from dbms1, but not deleted from R_b and R_{ab} in the idbm due to the deletion constraint of the reference in dbms2. These tuples are not visible to dbms1.

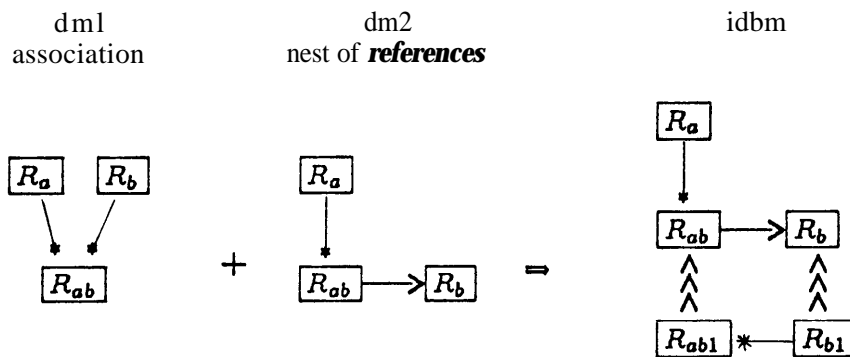

Figure 10a. Integration of association and **nest** of references

The database submodels now obey the following rules. Insertion and deletion in R_a from either **dbsm1** or **dbsm2** is unrestricted, as is deletion of R_{ab} tuples, and unreferenced R_b tuples. If **dbsm1** deletes a referenced R_b tuple (**dbsm2** may not perform such a deletion), it is only **deleted** from R_{b1} (and the owned tuples are deleted from R_{ab1}). These rules accurately **reflect** the constraints imposed by the views represented in the original data models.

For brevity, we will use the following format for **each** integration **case**. We first list the differences between the two data models, then list the additional integrity constraints that **have** to exist in the mapping from the database submodels to the integrated database model. When listing these additional constraints, ('relation name') will mean: do the insertion or deletion specified on "**relation**" if allowed by the integrity constraints of the **idbm**.

We will now present the demonstration case again in brief notation.

(a) ASSOCIATION AND NEST OF REFERENCES (figure 10a):

Differences:

Dml may **freely delete** tuples from R_b , while in dm2, deletion of R_b tuples is restricted.

Additional constraints:

dbsm1:

insert: (1) $R_b - R_b, R_{b1}$, (2) $R_{ab} - (R_{ab}, R_{ab1})$

delete: (1) $R_b - (R_b), R_{b1}$

dbsm2:

insert: (1) $R_b - R_b, R_{b1}$, (2) $R_{ab} - (R_{ab}, (R_{ab1}))$

The relation **name** to the left of the "-" refers to the database submodel, while those to the right **refer** to the database model. We only consider **cases** which **need** additional control from the constraints. Insert in R_a of **dbsm1** hence means insert in R_a of the **idbm**, since it is not listed. In **dbsm1**, insert in R_b requires insertion of the tuple in both R_b and R_{b1} of the **idbm**. Insert in R_{ab} requires insertion in (R_{ab}, R_{ab1}) in the **idbm**, the () brackets meaning if the integrity check of the **idbm** will allow it, **here** if both owner tuples exist. In **dbsm2**, insert in R_{ab} requires insertion in $(R_{ab}, (R_{ab1}))$, which means: insert the tuple in R_{ab} if the integrity check of the **idbm** holds (here both the owner tuple in R_a and the referenced tuple in R_b exist), then insert the same tuple in R_{ab1} (if the other owner tuple exists in R_{b1}).

Following each integration case, we will give an example with attributes to illustrate the integration process. Example 1 illustrates the integration of association and **nest** of references.

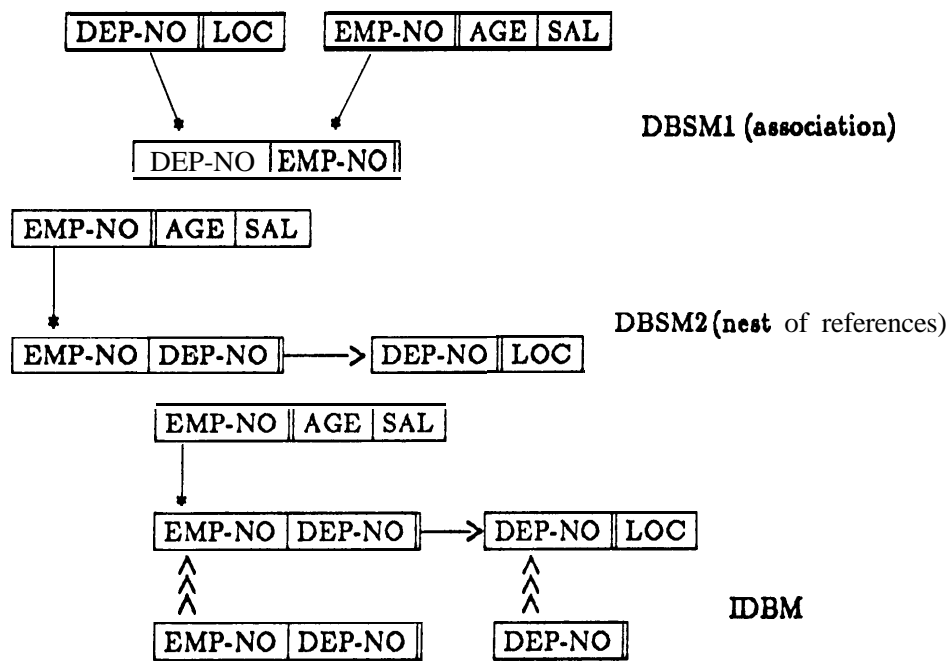

Example 1

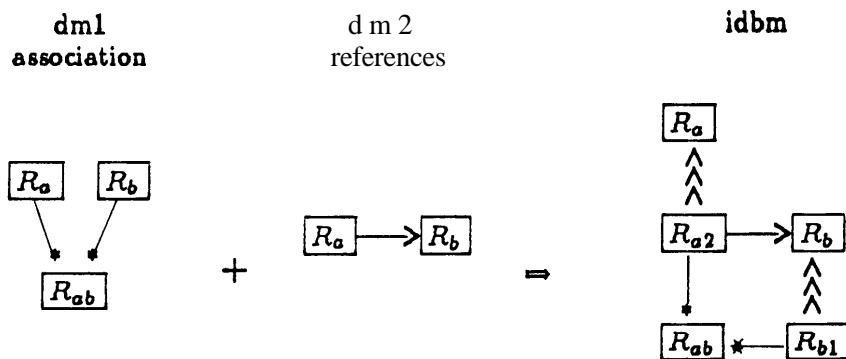

Figure 10b. Integration of association and reference

(b) ASSOCIATION AND REFERENCE (figure 10b):

The cardinality of the relationship **A:B** is restricted to **N:1**, since the **reference cannot represent an M:N** relationship,

Differences:

- (1) In dm2, every **R_a** tuple must reference an **R_b** tuple, while in dml not **all R_a tuples have** to be associated with **R_b tuples**.
- (2) In dm2, deletion of **R_b** tuples is restricted by references.

Additional constraints:

dbsml:

insert: (1) **R_b - R_b, R_{b1}**, (2) **R_{ab} - (R_{a2}, R_{ab})**

delete: (1) **R_b - (R_b, R_{b1})**, (2) **R_{ab} - R_{a2}, R_{ab}**

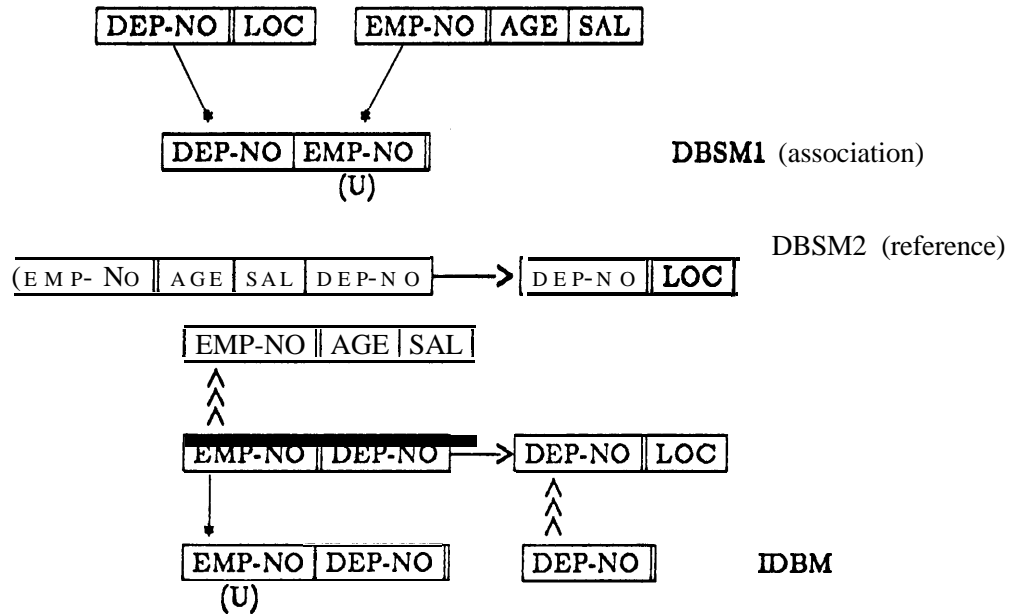

Example 2

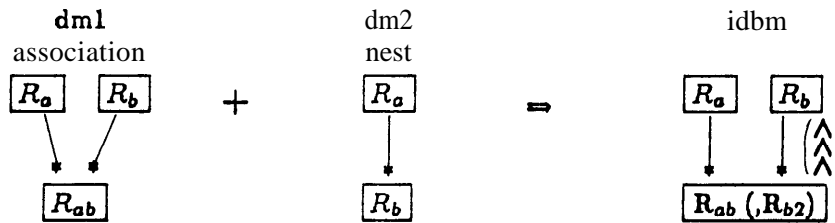

Figure 10c. Integration of association and nest

dbsm2:

insert: (1) $R_a - (R_a, R_{a2}, (R_{ab}))$, (2) $R_b - R_b, R_{b1}$

The requirement that every R_a tuple must reference an R_b tuple in dm2 leads to the creation of the subrelation R_{a2} , while the unrestricted deletion of R_b tuples in dml leads to the creation of R_{b1} (example 2).

(c) ASSOCIATION AND NEST (figure 10c):

The cardinality of the relationship $A:B$ is restricted to $1:N$, since the ownership connection can only represent $1:N$ relationships.

Differences:

- (1) In dm2, existence of a tuple in R_b requires the existence of the owner tuple in R_a , while in dml, R_b tuples can exist independently.
- (2) In dm2, deletion of a tuple from R_a requires the deletion of the owned tuple in R_b , while dml does not require these deletions.

Additional constraints:

dbsm2:

insert: $R_b - (R_b, R_{b2})$

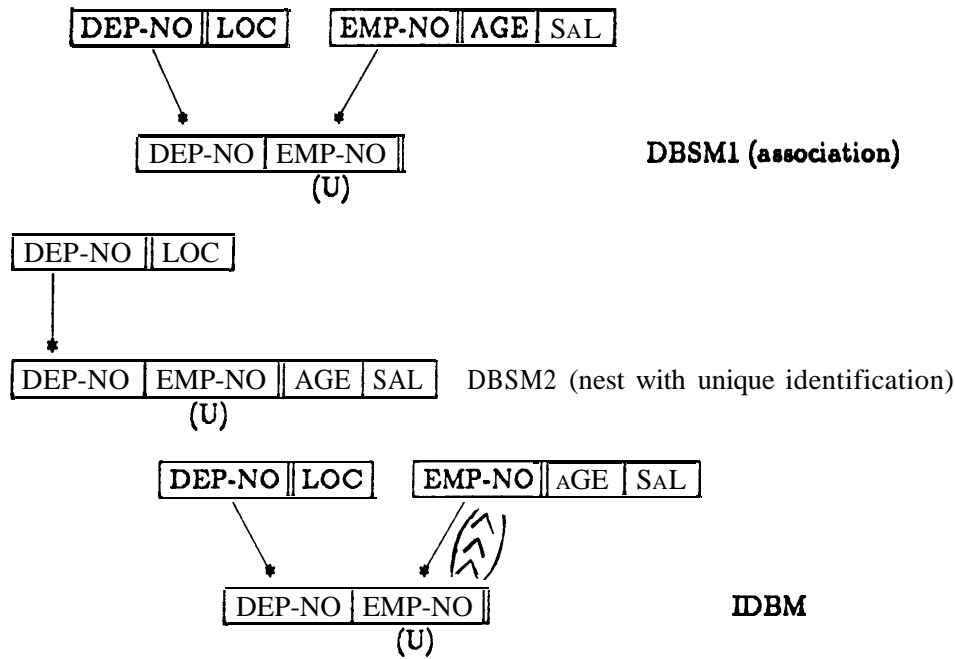

Example 3

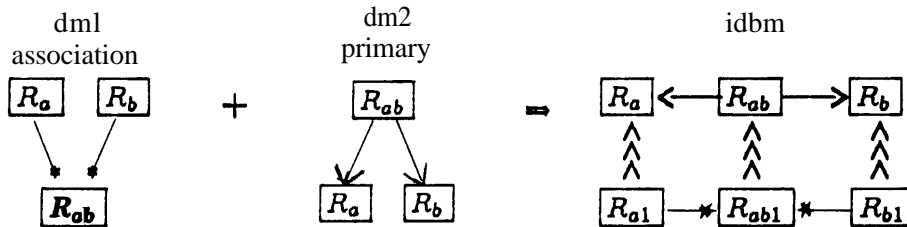

Figure 10d. Integration of association and primary

The R_b tuples of *dbsm2* are only those in R_{b2} in the *idbm*, since they require the existence of the owner tuple. In the *idbm*, R_{ab} will also represent the subset of R_b tuples in R_{b2} .

Here, we must consider two examples, since the nest relation may represent different tuple identification attributes than the association. First, we consider the case where the identification is the same. In example 3, EMP-NO identifies the employee in both *dbsm1* and *dbsm2*. Since the cardinality of DEPARTMENT:EMPLOYEE is 1:N, the EMP-NO attribute must have unique values in tuples of the relations marked (U). Note that this does not violate Boyce-Codd normal form. In this case, the integration is straightforward.

In example 4, the identifying information is different. *Dbsm2* uses the two attributes (EMP-NO, CHILD-NAME) as ruling part, while *dbsm1* uses only CHILD-ID. CHILD-ID uniquely identifies every child tuple, but CHILD-NAME does not. Here, if *dbsm2* does not represent the attribute CHILD-ID, he has to be made aware of it to maintain the correct mapping between CHILD-ID and CHILD-NAME on insertion of child tuples.

(d) ASSOCIATION AND PRIMARY (figure 10d):

The cardinality of the relationship A:B is M:N.

Differences:

In *dm2*, deletion of R_a and R_b is restricted by references

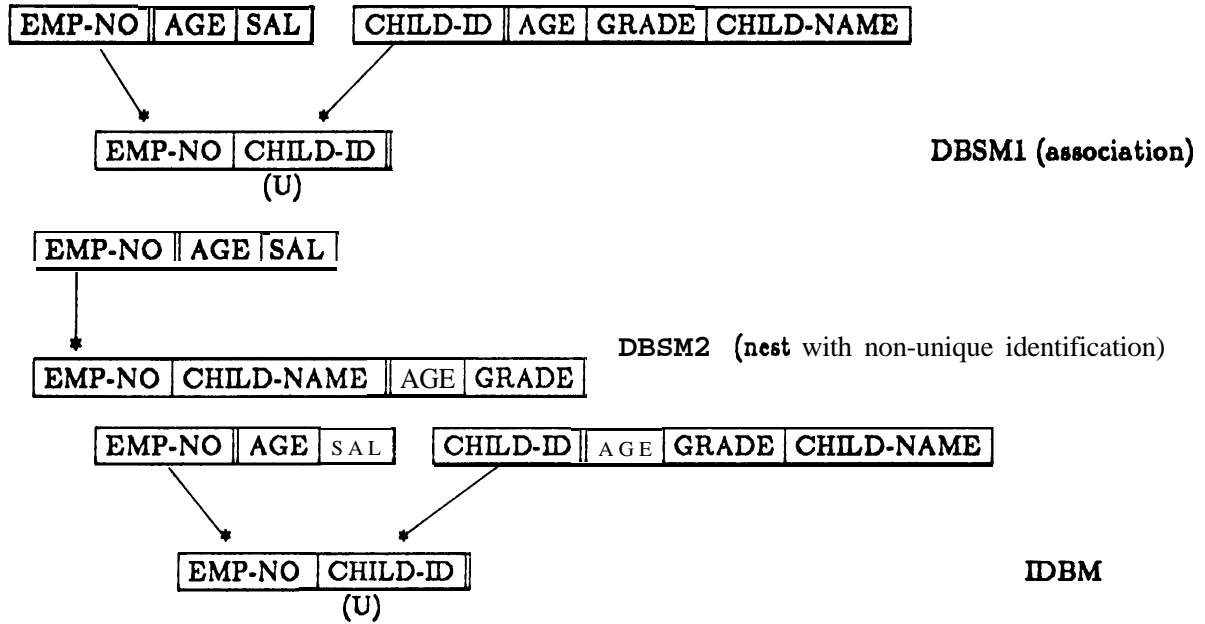

Example 4

Additional constraints:

dbsm1:

insert: (1) $R_a - R_a, R_{a1}$, (2) $R_b - R_b, R_{b1}$, (3) $R_{ab} - R_{ab}, R_{ab1}$

delete: (1) $R_a - (R_a), R_{a1}$, (2) $R_b - (R_b), R_{b1}$

dbsm2:

insert: (1) $R_a - R_a, R_{a1}$, (2) $R_b - R_b, R_{b1}$, (3) $R_{ab} - R_{ab}, R_{ab1}$

5.3.2. Integration with a nest of references:

Now we consider the cases that remain with nest of references. Dml represents the relationship $A:B$ as a nest of references, and dm2 represent it differently. The cardinality of the nest of reference representation is $M:N$, but may again be restricted by the representation in dm2. The nest of reference representation is not symmetric with respect to entity classes A and B, and so we must consider it twice with each non-symmetric representation.

(a) NEST OF REFERENCES AND NEST OF REFERENCES (figure 11a):

Differences:

(1) Deletion of R_b (R_b) is restricted in dml (dm2).

(2) Deletion of R_a (R_b) in dml (dm2) requires deletion of owned tuple in R_{ab} (R_{ba}).

Additional constraints:

dbsm1:

insert: (1) $R_a - R_a, R_{a1}$, (2) $R_b - R_b, R_{b2}$, (3) $R_{ab} - (R_{ab}, R_{ab1}, (R_{ba2}))$

delete: (1) $R_a - (R_a), R_{a1}, (R_{ab})$, (2) $R_b - (R_b, R_{ab})$.

dbsm2:

insert: (1) $R_a - R_a, R_{a1}$, (2) $R_b - R_b, R_{b2}$, (3) $R_{ba} - (R_{ab}, R_{ba2}, (R_{ab1}))$.

delete: (1) $R_a - (R_a, R_{ab})$, (2) $R_b - (R_b), R_{b2}, (R_{ab})$.

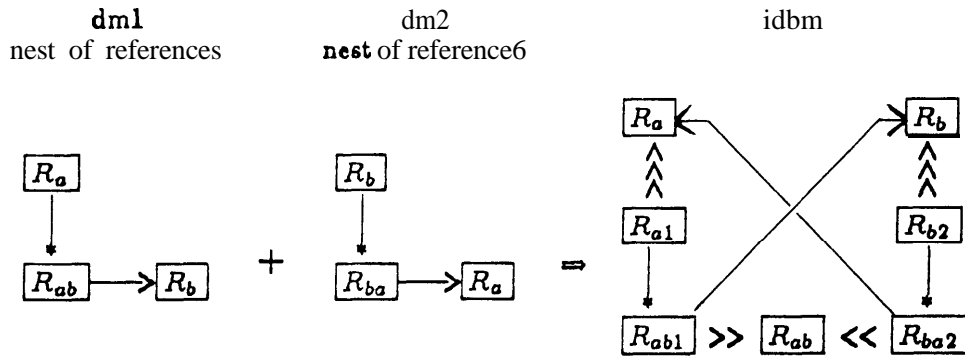
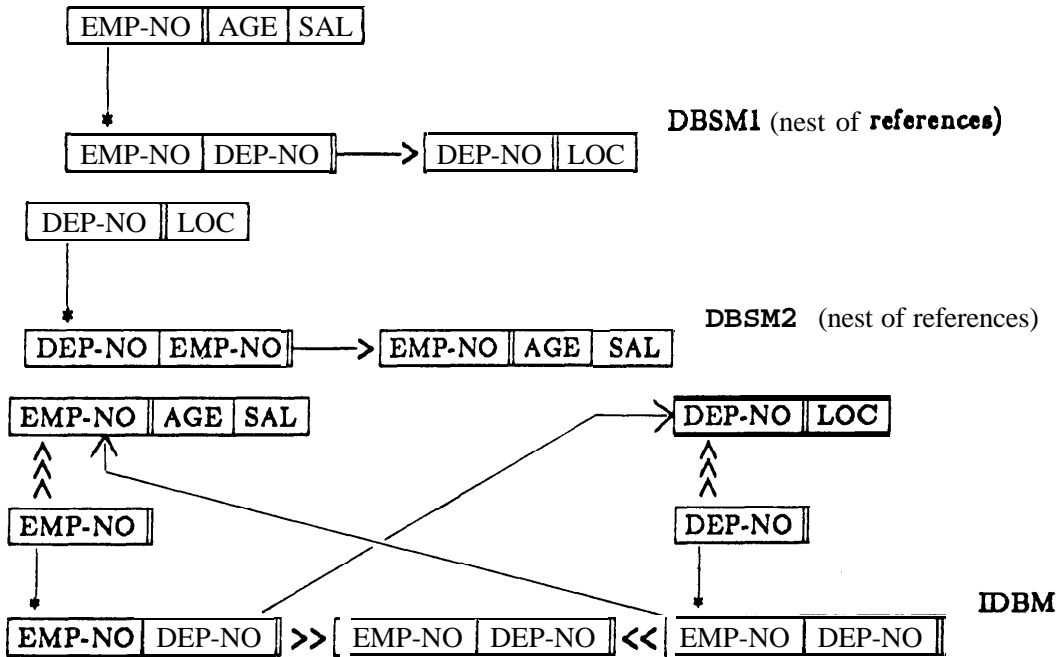

Figure 11a. Integration of **nest of references** and nest of references



Example 5

When **dbsm1** tries to delete an R_a tuple in the **idbm** that is referenced from R_{ba2} , it is only deleted from R_{a1} . If the tuple is not referenced from R_{ba2} , the tuples in R_{ab} that correspond to those deleted from R_{ab1} (due to the deletion of R_a) should also be deleted, since they no longer exist in either R_{ab1} or R_{ab2} . R_{ab} exists to ensure that the tuples associating tuples from R_a with tuple from R_b are consistent.

Example 5 illustrates this case.

(b) NEST OF REFERENCES AND REFERENCE (figure 11b, 11c):

Both nest of references and reference are non-symmetric, so we must examine two cases.

Case 1 (figure 11b):

The cardinality of the relationship $A:B$ is restricted to $N:1$, since the reference cannot represent an $N:M$ relationship.

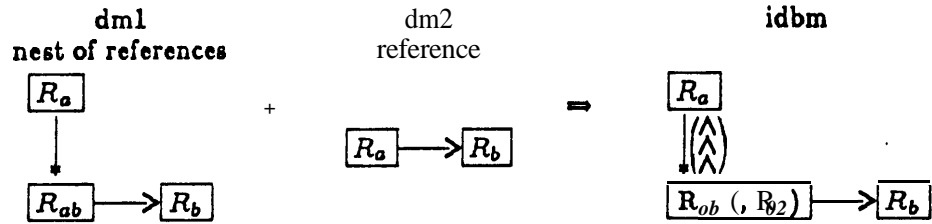
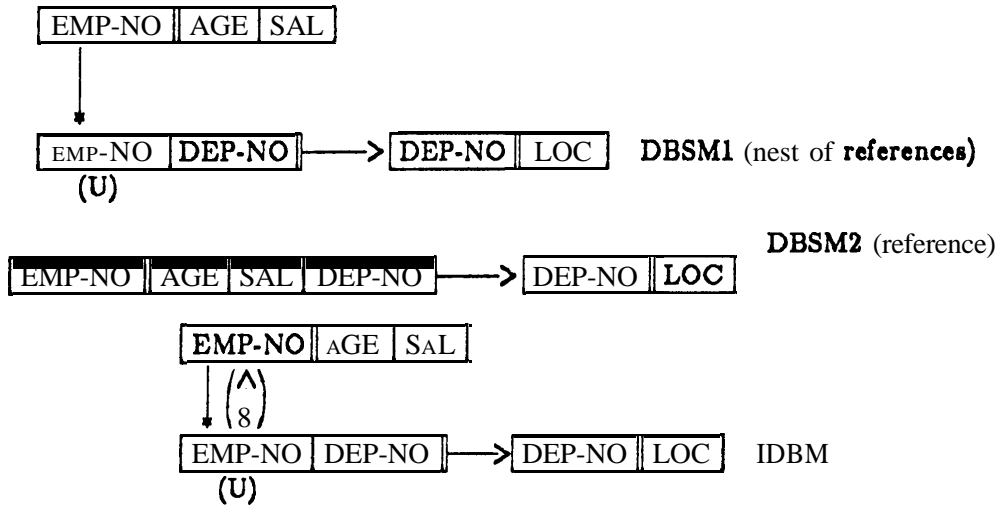

Figure 11 b. Integration of nest of references and reference (Case 1)



Example 6

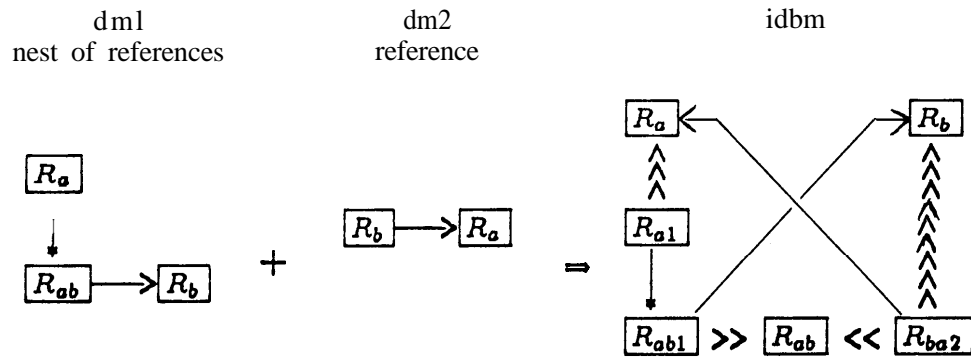

Figure 11c. Integration of nest of references and reference (Case 2)

Differences:

A tuple in R_a in dm2 must be associated with an R_b tuple.

Additional constraints:

dbsm2:

insert: $R_a - (R_a, R_{a2})$

Case 2 (figure 11c):

Again, the cardinality of the relationship $A:B$ is restricted to $1:N$.

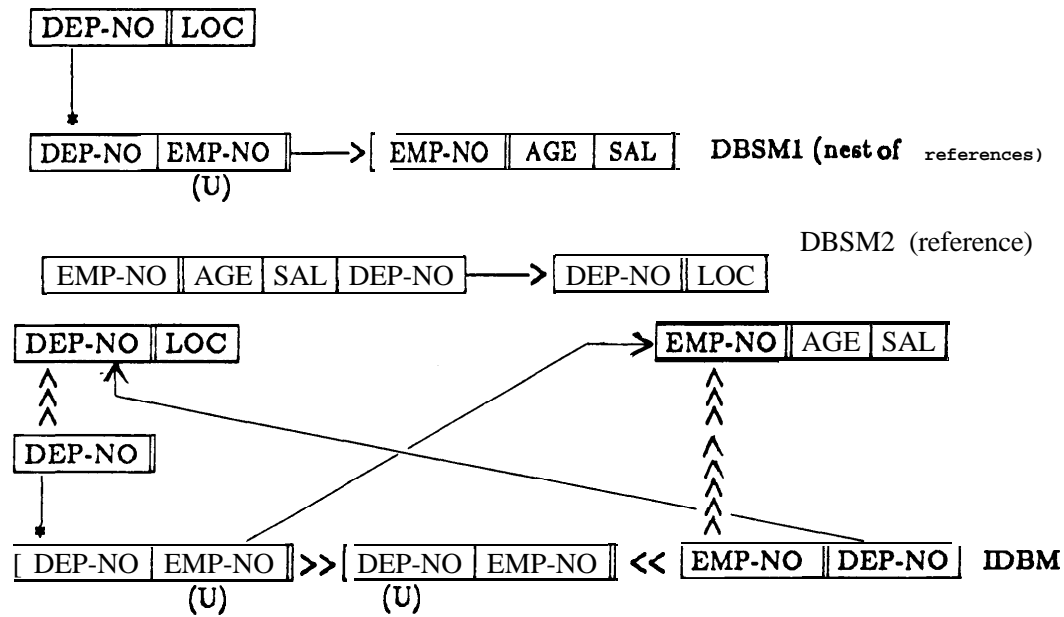

Example 7

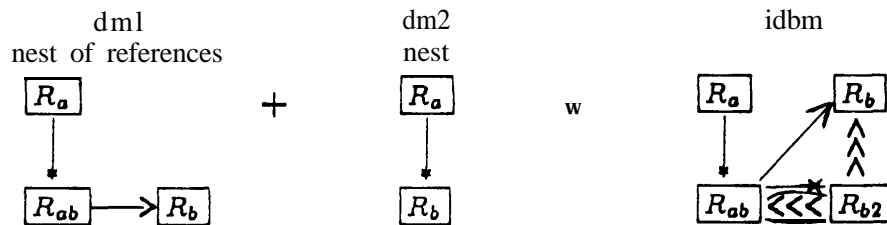

Figure 11d. Integration of nest of references and nest (Case 1)

Differences:

- (1) Deletion of R_b (R_a) tuples is restricted in dml (dm2).
- (2) Every R_b tuple in dm2 must be related to an R_a tuple.

Additional constraints:

dbsm1:

insert: (1) $R_a - R_a, R_{a1}$, (2) $R_{ab} - (R_{ab1}, R_{ab}, R_{b2})$.

delete: (1) $R_a - (R_a), R_{a1}, (R_{ab})$, (2) $R_b - (R_b, R_{ab})$, (3) $R_{ab} - R_{ab1}, (R_{ab})$.

dbsm2:

insert: (1) $R_a - R_a, R_{a1}$, (2) $R_b - (R_b, R_{b2}, R_{ab}, R_{ab1})$.

delete: (1) $R_a - (R_a, R_{ab})$, (2) $R_b - (R_b, R_{ab}), R_{b2}$.

Example 7 illustrates this case.

(c) NEST OF REFERENCES AND NEST (figure 11d, 11e):

Again, both nest of references and nest are non-symmetric, so we must examine two cases.

Case 1 (figure 11d):

The cardinality of the relationship $A:B$ is restricted to $1:N$, since the reference cannot represent an $N:M$ relationship.

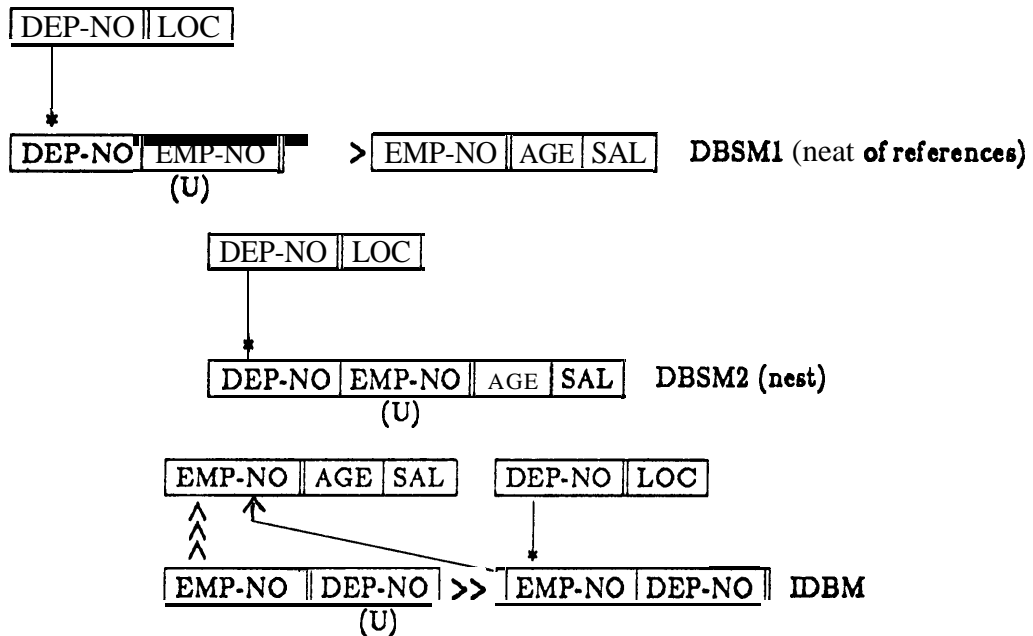

Example 8

Differences:

- (1) R_b tuples may exist independently in dml.
- (2) Deletion of R_b tuples is restricted in dml.

Additional constraints:

dbsm1:

insert: $R_{ab} - (R_{ab}, R_{b2})$.

dbsm2:

insert: $R_b - (R_b, R_{ab}, R_{b2})$.

delete: $R_b - (R_b), R_{b2}$.

We again consider two examples, because of the different ways the **nest** relation may represent the tuple identifying information. In **example 8**, we consider the case where the identifying information is the same.

In **example 9**, we now consider the case where the identifying information is different. Here, we must slightly change dm2 by introducing an additional attribute.

Case 2 (figure 11c):

The **cardinality** of the relationship **A:B** is restricted to **N:1**.

Differences:

- (1) In dml, R_a tuples can exist independently, while in dm2 an owner tuple R_b tuple must exist.
- (2) In dml, deletion of R_b tuples is restricted by references, while in dml, deletion of an R_b tuple requires deletion of related R_a tuples.

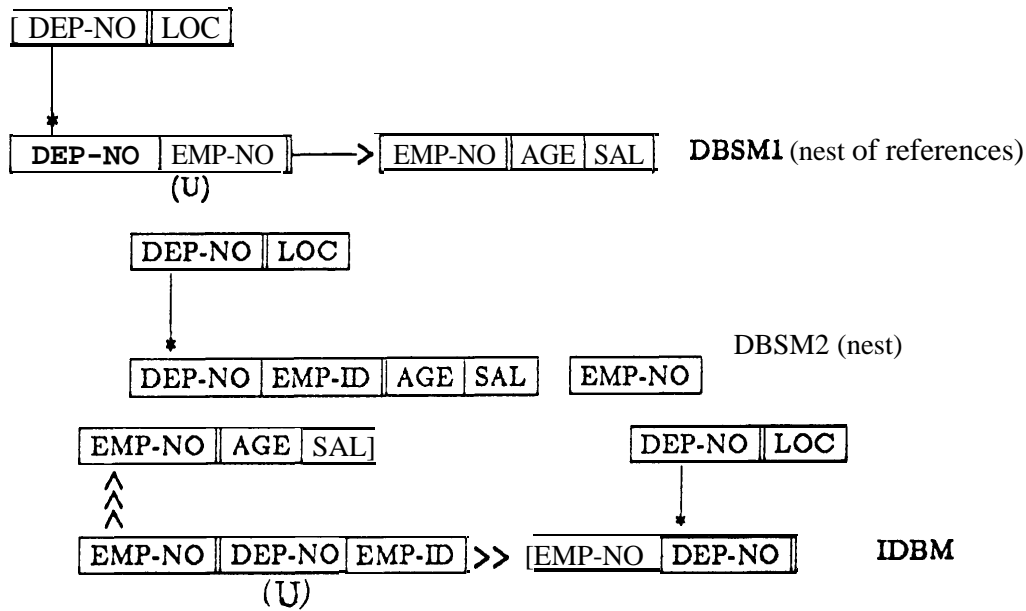

Example 9

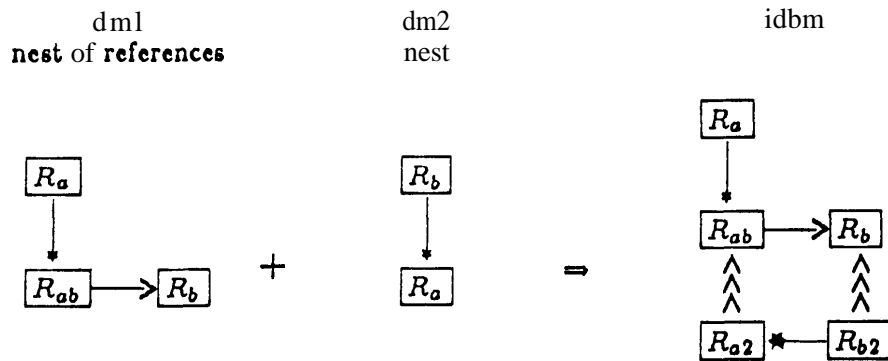

Figure 11e. Integration of nest of references and nest (Case 2)

Additional constraints:

dbsm1:

insert: (1) $R_b - R_b, R_{b2}$, (2) $R_{ab} - (R_{ab}, (R_{a2}))$.

dbsm2:

insert: (1) $R_a - (R_a, R_{a2}, R_{ab})$, (2) $R_b - R_b, R_{b2}$.

delete $R_b - (R_b), R_{b2}$.

We will only consider **one example** for this **case**, example 10, with different identification.

(d) NEST OF REFERENCES AND PRIMARY (figure 11f):

The **cardinality** of the relationship A:B is $M:N$.

Differences:

In dm2, deletion of R_a is restricted by references

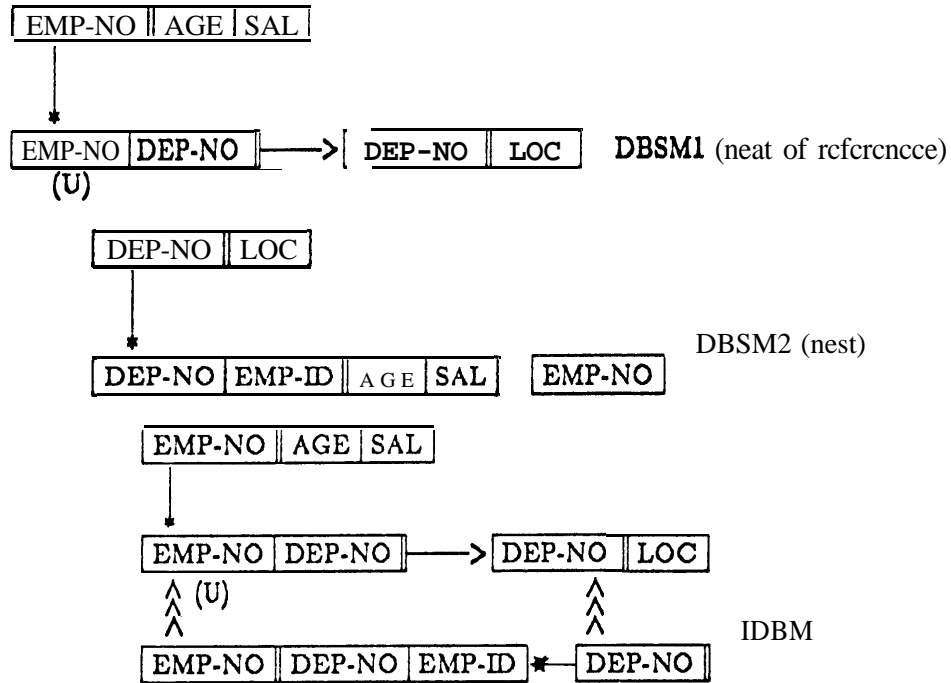

Example 10

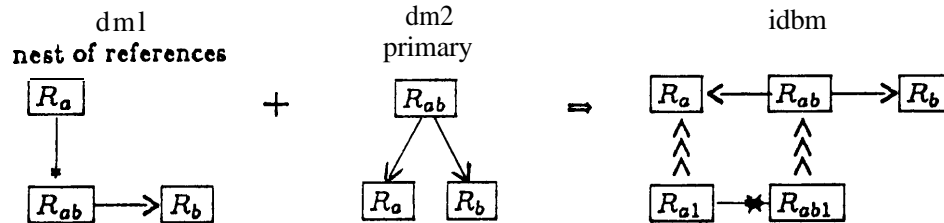

Figure 11f. Integration of **nest of** references and primary

Additional constraints:

dbsm1:

insert: (1) $R_a - R_a, R_{a1}$, (2) $R_{ab} - R_{ab}, R_{ab1}$

delete: (1) $R_a - (R), R_{a1}$

dbsm2:

insert: (1) $R_a - R_a, R_{a1}$, (2) $R_{ab} - R_{ab}, R_{ab1}$

5.3.3. Integration with a reference:

Dml represents the relationship **A:B** as a reference connection from R_a to R_b , and dm2 represents it using a different structure. The cardinality of the relationship **A:B** is **$N:1$** , possibly restricted by the dm2 representation.

(a) REFERENCE AND REFERENCE (figure 12a):

The cardinality of **A:B** is restricted to **$1:1$** , since in dml it is **$N:1$** , and in dm2 it is **$1:N$** . It would be unusual to encounter these two representations of the same **$1:1$** relationship. However, it can be integrated,

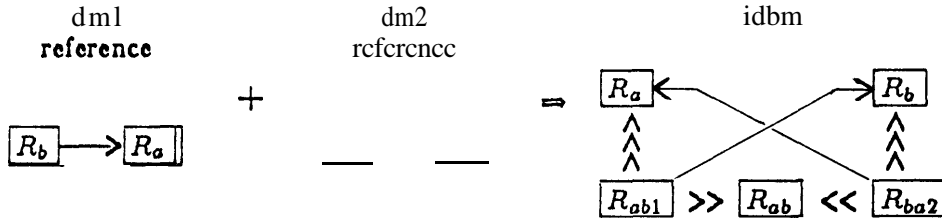

Figure 12a. Integration of rfrncnc and reference

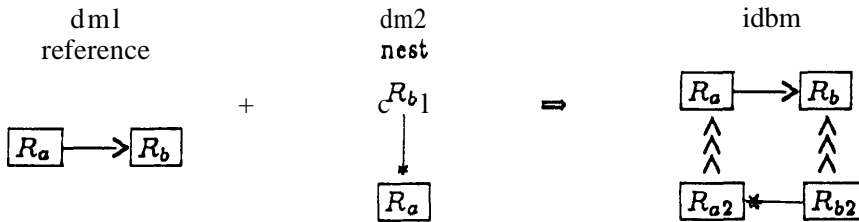
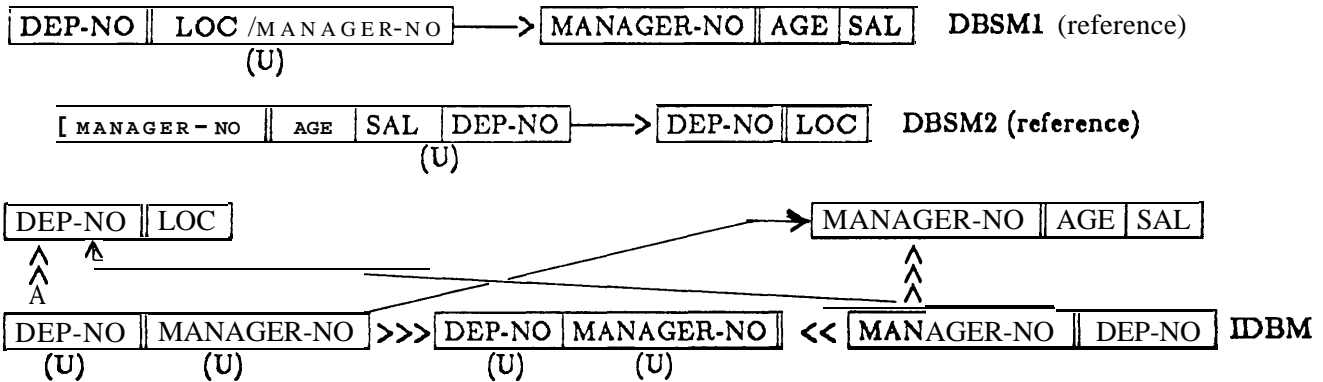

Figure 12b. Integration rfrncnc and nest (Case 1)

Differences:

- (1) In dml (dm2), every $R_a(R_b)$ tuple must reference an $R_b(R_a)$ tuple.
- (2) Deletion of $R_b(R_a)$ tuples is restricted in dml (dm2).

Additional constraints:

dbsm1:

insert: $R_a - (R_a, R_{a1}, R_{ab}, R_{b2})$.

delete: $R_a - (R_a), R_{a1}, (R_{ab})$.

dbsm2:

insert: $R_b - (R_b, R_{b2}, R_{ab}, R_{b2})$.

delete: $R_b - (R_b), R_{b2}, (R_{ab})$.

(b) REFERENCE AND NEST (figure 12b, 12c):

Case 1 (figure 12b):

The cardinality of the relationship $A:B$ is $N:1$.

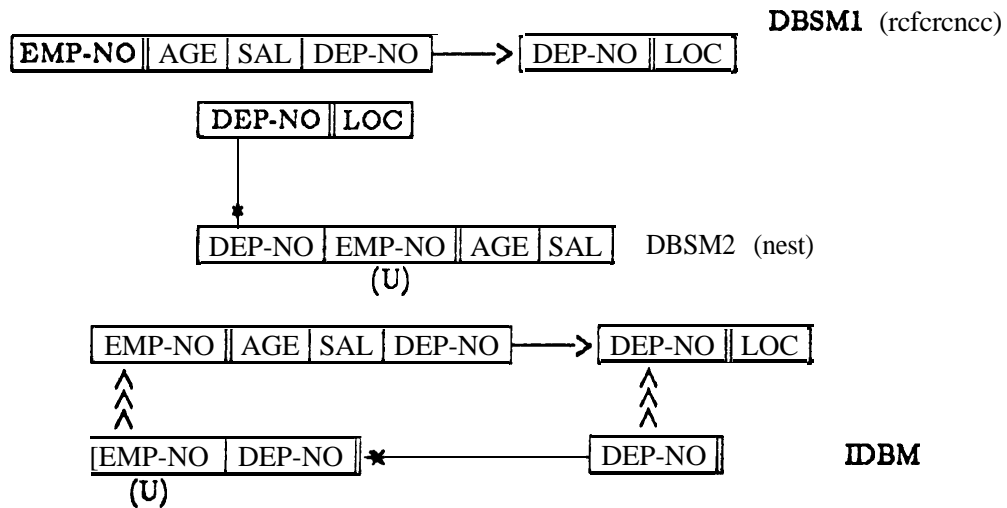

Example 12

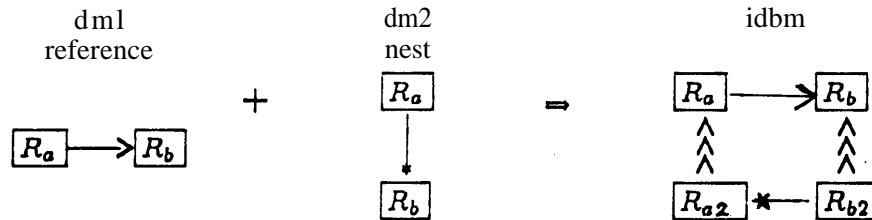

Figure 12c. Integration of reference and nest (Case 2)

Differences:

- (1) In **dbsm1**, deletion of R_b tuples is restricted by referencing.
- (2) In **dbsm2**, deletion of an R_b tuple requires deletion of related tuple in R_a .

Additional constraints:

dbsml:

insert: (1) $R_a - (R_a, (R_{a2}))$, $R_b - R_b, R_{b2}$.

dbsm2:

insert: $R_a - (R_a, R_{a2})$, $R_b - R_b, R_{b2}$.

delete: $R_b - (R_b), R_{b2}$.

Example 12 illustrates this case by a 1:N relationship between **DEPARTMENTS:EMPLOYEES**.

Case 2 (figure 12c):

The cardinality of the relationship **A:B** is restricted to **1:1**, since in dml it is **N:1**, and in dm2 it is **1:N**.

Differences:

- (1) Every R_a tuple in dml must reference an R_b tuple, while in dm2 every R_b tuple must be owned by an R_a tuple.
- (2) Deletion of R_b tuples is restricted in dml.
- (3) Deletion of an R_a tuple in dm2 requires deletion of owned R_b tuples.

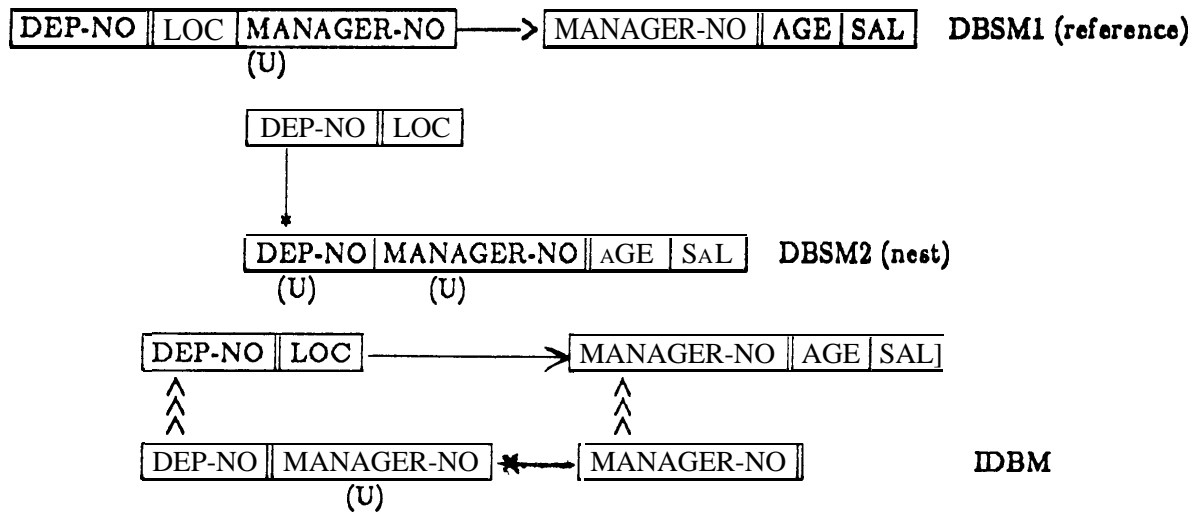

Example 13

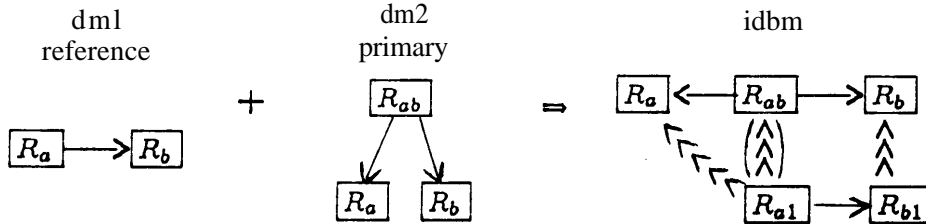

Figure 12d. Integration of reference and primary

Additional constraints:

dbsm1:

insert: $R_a - (R_a, R_{a1}, R_{b2})$

dbsm2:

insert: $R_b - (R_b, R_{a1}, R_{b2})$

delete: $R_b - (R_b), R_{b2}$

Example 13 illustrates this case,

(c) REFERENCE AND PRIMARY (figure 12d):

The cardinality of the relationship $A:B$ is $N:1$.

Differences:

In dm2, deletion of R_a is restricted by references

Additional constraints:

dbsm1:

insert: $R_b - R_b, (R_{b1})$

delete: (1) $R_b - (R_{b1}, (R_b))$

dbsm2:

insert: (1) $R_b - R_b, R_{b1}, (2) R_{ab} - R_{ab}, R_{a1}$

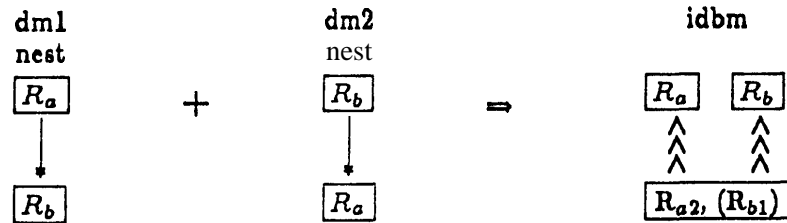
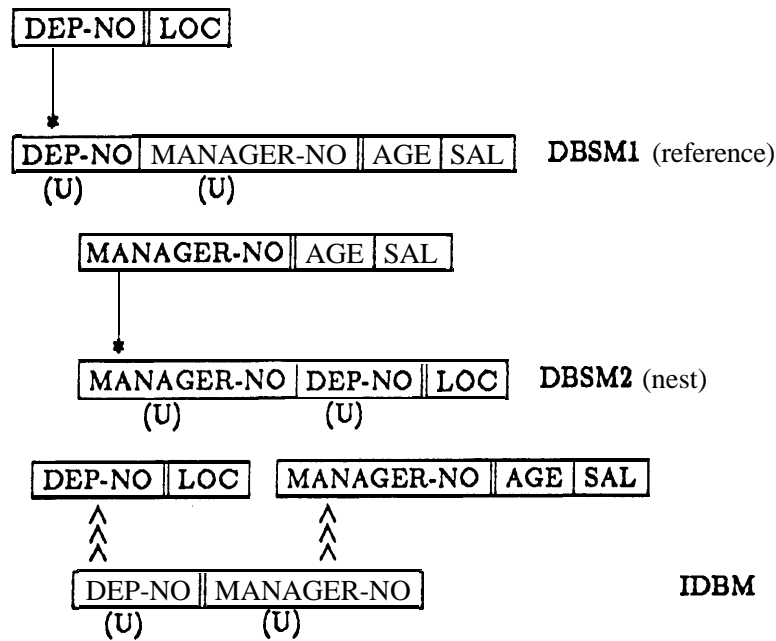

Figure 13a. Integration of nest and nest



Example 14

5.3.4. Integration with a nest:

(a) NEST AND NEST (figure 13a):

The cardinality of **A:B** is restricted to **1:1**.

Differences:

- (1) In dml (**dm2**), every **R_b(R_a)** tuple must be owned by an **R_a(R_b)** tuple.
- (2) Deletion of an **R_a(R_b)** tuple in dml (**dm2**) requires deletion of the owned **R_b(R_a)** tuple.

Additional constraints:

dbsm1:

insert: **R_b - (R_b, R_{b1})**

dbsm2:

insert: **R_a - (R_a, R_{a2})**

Example 14 illustrates this case.

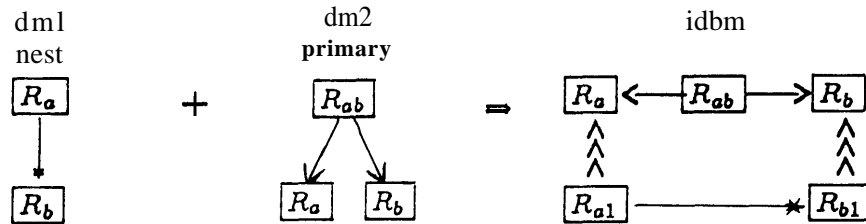

Figure 13b. Integration of nest and primary

(b) NEST AND PRIMARY (figure 13b):

The **cardinality** of the relationship **A:B** is **1:N**.

Differences:

- (1) In dm2, deletion of **R_a** is restricted by references
- (2) In dm2, deletion of an **R_a** tuple results in deletion of owned **R_b** tuples, while in dm1 deletion of **R_b** is restricted by references

Additional constraints:

dbsm1:

insert: (1) **R_a** - **R_a**, **R_{a1}**, (2) **R_b** - (**R_b**, **R_{b1}**)

delete: (1) **R_b** - **R_{b1}**, (**R_b**)

dbsm2:

insert: (1) **R_a** - **R_a**, **R_{a1}**, (2) **R_{ab}** - **R_{ab}**, **R_{b1}**

6. RELATIONSHIP TO OTHER MODELS

In this section, we examine some of the similarities **between** the structural model and other data models.

6.1. The relational model:

In relational model theory, the concepts of functional [Codd72] and multivalued [Fagin77] dependency among attributes are important for normalization of relations and data model design. A functional dependency between two attributes A_1 and A_2 , denoted by $A_1 \Rightarrow A_2$, means that for each value of $DOM(A_1)$, a unique corresponding value of $DOM(A_2)$ can be determined. Functional dependency between two sets of attributes is defined correspondingly. Attributes of a relation R in Boyce-Codd normal form obey the constraint: if any attribute A in R is functionally dependent on a set of attributes X in R , and A is not in the set X , then all attributes *in* R are functionally dependent on X .

All relations in the structural model are in Boyce-Codd normal form, and hence obey the above constraint. A functional dependency will also exist between each attribute in a referenced relation, and the ruling part of the referencing relation. Hence, a reference connection from a relation R to another relation $R'[A_1, \dots, A_i]$ defines i functional dependencies $K(R) \Rightarrow A_j; j = 1, \dots, i$. This is so because a functional dependency $K(R) \Rightarrow X_r$ will exist in relation R , where X_r is the set of referencing attributes in R . We will also have the functional dependencies $X_r \Rightarrow K(R')$ and $K(R') \Rightarrow A_j; j = 1, \dots, i$. From the transitivity rule for functional dependencies, it follows that $K(R) \Rightarrow A_j; j = 1, \dots, i$.

Since the structural model is constructed from relations, a relational query system based on the relational algebra or the relational calculus can be used on the structural model. However, additional capabilities exist in the structural representation to simplify expression of queries by making use of represented connections. For example, consider the structural schema in figure 8a. A query such as 'FIND THE WORK LOCATION OF EMPLOYEE NUMBER 5' does not have to be expressed as a join between two relations, since the reference connection specifies the department tuple that corresponds to the tuple representing employee number 5.

In the relational model, one has to specify integrity constraints to maintain tuples in different relations in a consistent state. In the structural models, such constraints may be specified implicitly via connections.

6.2. The hierarchical model:

A hierarchical model can be expressed using relations as record types and ownership connections as hierarchical arcs. Hence, if a structural model is restricted such that only ownership connections are used, and such that all relations are connected together in a tree structure, a hierarchical definition tree would result. The difference in representation is the redundancy created by repetition of the ruling part attribute of the owner relations in the owned relations. However, such redundancy need not be implemented in a hierarchical implementation.

6.3. The network model:

The link set concept of the network model can be represented in the structural model. An automatic set can be defined using an ownership connection. Again, the only difference is the redundant representation of the ruling part attributes from the owner relation in the owned relation.

However, the existence of the connecting attributes implicitly specifies the set occurrence **when** a new member tuple is inserted in the data model without requiring an additional procedure to specify the correct owner.

A manual set can **be** represented by a **1:N** association between two relations, as in the **ex-**ample of figure 8d. Here, the DEPARTMENTS relation corresponds to the owner type, and the EMPLOYEES relation to the member type. Employee tuples can exist without belonging to any department **tuple**, and the set **OF** members of **each** department **owner** tuple is specified via the association.

The implementation oriented features of the hierarchical and network models are **implemen-****tation** dependent, and hence are best left to the implementation phase. We note that **the** structural model may represent structures that are not part of any of the **three** other models, as shown in section 4.2.

7. THE DATABASE DESIGN PROCESS

This section **summarizes the** process of designing the database with **the aid of the** structural model, and provides a brief discussion of **considerations** for model implementation. **The** approach, which we only outline here, provides much of **the** motivation for concepts presented in **the** structural model. A detailed description and analysis of **the** remaining steps of **the** database design process will be **the** subject of a later report.

An overview of **the** entire **design** process for an integrated database system **is** given in figure 14. We define **three** groups of people that partake in **the** design process: **the** potential **users**, the integrators, and **the** implementors. These groups will interact during the database design process. The vertical axis in figure 14 **defines the** activities of **each** group relative to a **time** frame.

A potential **user** is a group of **people** or application programs that **expect to use** the database system. Many such potential **users** will exist since we are designing a large, integrated database. Each potential **user** must **analyse his** requirements, and **define** a data model with expected load estimates. **Since** a database typically **serves** many diverse but potentially related interests, many such data models can **be** established.

In section 4.1, we showed how **the** structural model guides **the** design of data models. Additional information is solicited from **the** potential **user** about his expected **use** of his data model. This information is not part of **the** data model, but is attached to **the** relations and connections of his data model. This includes additional integrity constraints, and expected retrieval and update **characteristics for the** data model. Load estimates will **be** classified into several update and retrieval components on **the** relations and connections of the data model.

The database integrators **then** undertake to combine **these** data models into an integrated database model. In **the** process of combining the data models, conflicts may arise which **have to be** resolved by changing some of **the** data models. **There may be** data models which turn out to **be** unrelated, or **weakly** related, to the core of **the** integrated database model **so that they** are not included. **The** result of **the** data model integration is to define preliminary database submodels for **the user** groups. This process will need consultation with **the users** if their data model has to be changed.

The integrators then combine the load estimates from **the** individual **user** data models and produce load **estimates** for the database model. When the transformation from data models to database model is simple, **the** load estimates can simply **be** added together. In complex situations, load data will **have to be transformed** to correspond to **the** transformation from **the** data models to **the** database model.

The implementors then use the cumulative load estimates on relations and connections to design **the file** structures and access methods. **They take** into account **the** expected update and retrieval loads for **the database model**. Connections that are expected to **be used** frequently should **be** explicitly **represented** in **the** implementation. A **methodology** for designing **the file** structures and **access** methods based on **the** expected update and retrieval characteristics of relations and connections will **be** described in a later report.

When usage patterns change, it is reasonable to change implemented **file** structures and access methods without affecting **the** structural database **model**. Only the performance of retrieval and updates along model relations and connections whose implementation is changed will **be** affected. Provisions should **be made in the** implementation for such a restructuring.

Provisions must also be **made** for changing **user** data models, or for deletion of existing **submodels** and addition of new data models. This may **cause** a change in **the** database model. Structural model changes which only affect rarely **used** connections will **be easier** to accommodate than changes which affect **very** critical and tightly bound connections.

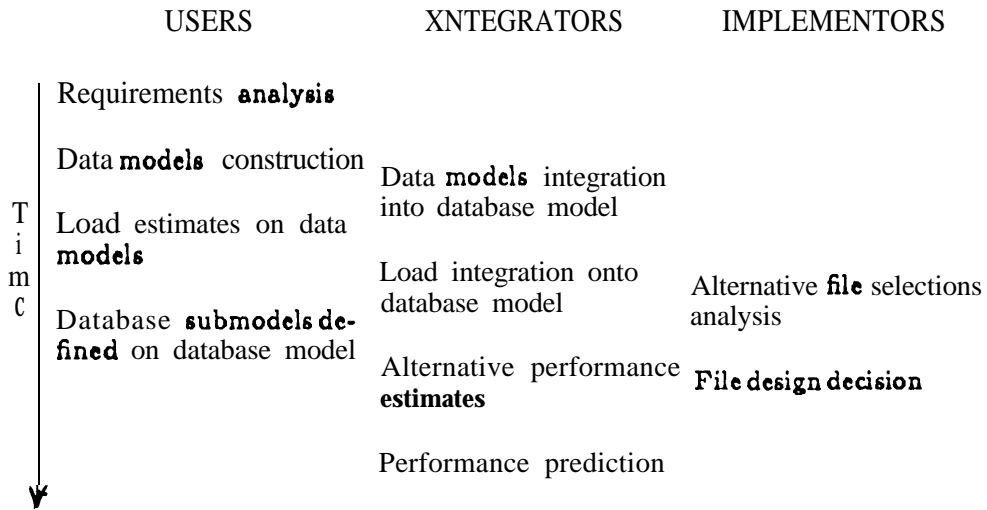

Figure 14. The integrated database design process

We will address the issue of database design and implementation using the structural model in a separate report. We will give a quantitative approach to database design, and discuss possible implementation choices for the structural model constructs.

8. Conclusions:

The model we have presented provides a bridge between the simplicity of the relational model and the explicitness of the network model. On the one hand, all structures in the model are relations in Boyce-Codd normal form so that the uniformity of the relational model is maintained. Query techniques devised for relational models can be easily incorporated into the structural model. On the other hand, important structural information about the real-world situation is incorporated in the data model, and provides important knowledge both for potential users and for database system implementors.

We then showed how the different representations in two data models can be integrated, leading to the construction of an integrated database model which correctly supports the different data models of the users. The integrated database model then supports the user submodels.

Our point of view of the implementation process is that connections between relations have to be carefully considered. Binding of important connections will cause reasonable levels of performance to be achieved. At the same time, unbound connections remain recognized, and may be employed when restructuring due to changing demands becomes necessary. The decision of which connections to bind is best supported by inclusion of connections which are candidates for binding in the database model.

References:

- [Abrial74] Abrial, J.R., "Data Semantics", in J.W.Klimbie and K.L.Koffeman (eds.), "Data Base Management" (Proc. IFIP Conf. on Data Base Management), North-Holland, 1974, pp.1-60
- [Chang78] Chang, S.-K. and W.-H.Cheng, "Database Skeleton and its Application to Logical Database Synthesis", IEEE Trans. on Software Engineering, Vol.SE-4, No.1, January 1978, pp.18-30
- [Chen76] Chen, P.P.S., "The Entity-Relationship Model - Towards a Unified View of Data", ACM Trans. on Database Systems, Vol.1, No.1, March 1976, pp.9-36
- [Codd70] Codd, E.F., "A Relational Model for Large Shared Data Banks", Comm. ACM, Vol.13, No.6, June 1970, pp.377-387
- [Codd72] Codd, E.F., "Further Normalization of the Data Base Relational Model", in R.Rustin (ed.), "Data Base Systems", Courant Comp. Sci. Symp., Volume 6, Prentice-Hall, 1972, pp.33-64
- [CODASYL74] CODASYL Data Description Language, Journal of Development (June 1973), National Bureau of Standards Handbook 113, Gov. Printing Office, Wash.D.C., Jan. 1974, 155 pp.
- [DeBlasis77] DeBlasis, J.P. and T&Johnson, "Data Base Administration - Classical Pattern, Some Experiences and Trends", Proc. NCC, 1977, AFXPS Vol.46, pp.1-7
- [Eswaran75] Eswaran, K.P. and D.D.Chamberlin, "Functional Specifications of a Subsystem for Database Integrity", in D.S.Kerr (ed.), "Very Large Data Bases", (Proc. Intl. Conf. on VLDB), ACM, 1975
- [Fagin77] Fagin, Ronald, "Multivalued Dependencies and a New Normal Form for Relational Databases", ACM Trans. on Database Systems, Vol.2, No.3, Sept. 1977, pp.262-278
- [Fry76] Fry, J.P. and E.H.Sibly, "Evolution of Data-Base Management Systems", ACM Comp. Surveys, Vol.8, No.1, March 1976, pp.70-82
- [Hammer78] Hammer, M. and D.McLeod, "The Semantic Data Model: A Modelling Mechanism for Data Base Applications", in E.Lowenthal and N.B.Dale (eds.), ACM SIGMOD Intl. Conf. on Management of Data, Austin, Texas, 1978, pp.26-36
- [Kent77] Kent, W., "New Criteria for the Conceptual Model", in P.C.Lockemann and E.J.Neuhold (eds.), "Systems for Large Data Bases" (Proc. 2nd Intl. Conf. on VLDB), North-Holland, 1977, pp.1-12
- [Manacher75] Manacher, S., "On the Feasibility of Implementing a Large Relational Data Base with Optimal Performance on a Mini-Computer", in D.S.Kerr (ed.), "Very Large Data Bases" (Proc. Intl. Conf. on VLDB), ACM, 1975, pp.175-201
- [Mylopoulos75] Mylopoulos, J. and N.Roussopoulos, "Using Semantic Networks for Data Base Management", in D.S.Kerr (ed.), "Very Large Data Bases", (Proc. Intl. Conf. on VLDB), ACM, 1975, pp.
- [Navathe78] Navathe, S.B. and M.Schkolnick, "View Representation in Logical Database Design", in E.Lowenthal and N.B.Dale (eds.), ACM SIGMOD Intl. Conf. on Management of Data, Austin, Texas, 1978, pp.144-156
- [Schmid75] Schmid, H.A. and J.R.Swenson, "On the semantics of the relational model", in W.F.King (ed.), ACM SIGMOD Intl. Conf. on Management of Data, San Jose, California, 1975, pp.211-223
- [Sibley76] Sibley, E.H., "The Development of Database Technology", ACM Computing Surveys, Vol.8, No.1, March 1976, pp.1-7

- [Smith77] Smith, J.M. and D.C.P.Smith, 'Database Abstractions: Aggregation **and Generalization**', ACM Trans. on Database Systems, Vol.2, No.2, June 1977, pp.105-133
- [Steel75] Steel, T.B., Jr., "ANSI/X3/SPARC Study Group on Data **Base** Management Systems Interim Report", FDT (pub. ACM SIGMOD), Vol.7, No.2, 1975
- [Stonebraker74] Stonebraker, M., "High level integrity assurance in relational data **base management systems**", Electronic Research Lab. report ERL-M473, University of California, Berkeley, California, May 1974
- [Taylor76] Taylor, R.W. and R.L.Frank, "CODASYL Data-Base Management **Systems**", ACM Computing Surveys, Vol.8, No.1, March 1976, pp.670-104
- [Tsichritzis76] Tsichritzis, D.C. and F.H.Lochofsky, 'Hierarchical Data-Base Management', ACM Comp. Surveys, Vol.8, No.1, March 1976, pp.105-124
- [Tsichritzis77] Tsichritzis, D. and F.Lochofsky, "Views on Data", in D.Jardine (ed.), "The ANSI/SPARC DBMS Model", North-Holland, 1977, pp.51-65
- [Wiederhold77] Wiederhold, G., 'Database **Design**', McGraw-Hill, 1977, Chapter 7, pp.329-367
- [Wiederhold78] Wiederhold, G., 'Management of Semantic Information for Databases', Proc. 3rd USA-Japan **Comp. Conf., AFIPS & IPSJ**, San **Francisco**, California, 1978, pp.192-197

